

Fiilex®

K10 COLOR

USER MANUAL



Model No:FLXK10CLR
900W LED Punch Light

English Version
Rev.01 - 02/18/2025

Thank you for choosing Fiilex

Please note that every Fiilex product has been designed in the USA to meet quality and performance requirements for professionals and manufactured for the use and application as shown in this document.

Any other use, if not expressly indicated, could compromise the condition and operation of the product and/or be a source of danger.

This product is meant for professional use. Therefore, commercial use of this equipment is subject to applicable national accident prevention rules and regulations.

Features, specifications, and appearance are subject to change without notice. Fiilex and all affiliated companies are not liable for for any injury, damage, direct or indirect loss, consequential or economic loss or any other loss occasioned by the use of, inability to use or reliance on the information contained in this document.

Product datasheets can be downloaded from the website www.filex.com or can be received from the official Fiilex customer service team (Fiilex@filex.com).

For the most up-to-date technical documentation including specifications, datasheets, technical drawings, photometrics, DMX personalities, and fixture firmware updates, as well as a full list of authorized distributors and repair centers worldwide, please visit www.filex.com or contact the customer service team.

SERVICE ADDRESS

US, Fiilex	Germany, Lightpower	France, Innport	UK, Cirrolite
1689 Regatta Blvd.	An der Talle 24-28	11B Rue de Berlin	3 Barretts Green Road
Richmond, CA 94804	D-33102 Paderborn	Parc Aquatechnique	London NW10 7AE
USA	Germany	34200 SÈTE Hérault, France	United Kingdom
(510) 620 5155	+49 5251 1432 0	+33 0 980 749 802	+44 20 8955 6700
filex@filex.com	sales@lightpower.de	contact@innport.eu	info@cirrolite.com

The Fiilex Logo, Fiilex names, and all other trademarks in this document pertaining to Fiilex services or Fiilex products are trademarks of DiCon FiberOptics, Inc., its affiliates, and subsidiaries. Fiilex is a registered trademark. All rights reserved. DiCon FiberOptics 1689 Regatta Blvd. Richmond, CA 94804 USA

INDEX

INTRODUCTION	02
INDEX	03
SAFETY INFORMATION	05
WARRANTY	08
1 - PACKAGING	09
PACKAGE CONTENTS	09
OPTIONAL ACCESSORIES	09
2 - SPECIFICATIONS	09
3 - TECHNICAL DRAWING INFORMATION	10
4 - PHOTOMETRIC DATA	10
5 - BEAM PROFILE	11
6 - INSTALLATION	12
MOUNTING	12
8 - START UP	13
CONNECT AND DISCONNECT POWER	13
9 - PRODUCT OVERVIEW	14
PARTS DIAGRAM	14
10 - CONTROL PANEL	15
DISPLAY AND BUTTON LAYOUT	15
KNOB FUNCTION	16
KNOB BEHAVIOR FOR ALL MODES	16
11 - DMX CONNECTION	17
CONNECTION OF THE DMX SIGNAL	17
INSTRUCTIONS FOR A RELIABLE DMX CONNECTION	17
DAISY CHAINING	17
DMX TERMINATION	18
DMX ADDRESSING	18
12 - MENU STRUCTURE	19
MENU	19
13 - DMX MAPPING	21
NOTES	21
K10 Control Table	22

DMX MODES	23
14 - RDM FUNCTIONS	68
15 - ACCESSORIES ADJUSTMENTS	76
ADDITIONAL ACCESSORIES	78
16 - MAINTENANCE	79
MAINTENANCE AND CLEANING	79
VISUAL CHECK OF PRODUCT HOUSING	80
17 - TROUBLESHOOTING	81
18 - ERROR CODES LIST	82

SAFETY INFORMATION

IMPORTANT Read carefully before use and keep for future reference.



This unit is only for professional applications. It is not for household use.



Connection to AC power supply:

- The connection to the AC power supply must be carried out by a qualified electrical installer.
- Use only 100-240V AC, 50-60 Hz input. Ensure the fixture is properly grounded.
- Ensure the electrical system is appropriately sized to the maximum current draw of the product and the possible number of products connected at the same circuit.
- Do not connect the product to a dimmer system; doing so may damage the product.



Protection and Warning against electrical shock

- Do not remove the housing of the product. Always disconnect the product from AC power before servicing.
- Ensure that the fixture is properly grounded.
- Ensure the source of AC power complies with local building and electrical codes and has both overload and ground-fault protection.
- Before using the fixture, check that all power distribution equipment and cables are in perfect condition and rated for the current requirements of all connected devices.
- Remove the fixture from power immediately if the power plug or any seal, cover, cable, or other components are damaged, defective, deformed, or showing signs of overheating.
- Do not reapply power until repairs have been completed.
- Refer any service operation not described in this manual to the Fiilex Customer Service team.



Installation

- Make sure that all visible parts of the product are in good condition before its use or installation.
- Make sure the point of anchorage is stable before positioning the fixture.
- When suspending the fixture above ground level, secure it against failure of primary attachments by attaching a safety cable that is approved as a safety attachment for the weight of the fixture.
- Install the product only in well-ventilated places.
- For non temporary installations ensure that the fixture is securely fastened to a load-bearing surface with suitable corrosion-resistant hardware.
- For a temporary installation with clamps, ensure that all fasteners and/or screws are secured fully, and the fixture is secured with a suitable safety cable.



Protection from burns and fire

- The exterior of the fixture becomes hot during use. Avoid contact with persons and materials.
- Ensure that there is free and unobstructed airflow around the fixture.
- Keep flammable materials well away from the fixture.
- Do not expose the front lens to sunlight or any other strong light source from any angle.
- Lenses can focus the sun's rays inside the fixture, creating a potential fire hazard.
- Do not attempt to bypass thermostatic switches or fuses.

SAFETY INFORMATION



Maintenance

- **Warning!** Disconnect the fixture from AC power and allow it to cool for at least 10 minutes before handling.
- Only technicians who are authorized by Fiilex or Authorized service partners are permitted to open the fixture.
- Users may carry out external cleaning, following the warnings and instructions provided, but any service operation not described in this manual must be referred to a qualified service technician.
- Important! Excessive dust, smoke fluid, and particle build-up all degrade performance, cause overheating, and will damage the fixture. Damages caused by inadequate cleaning or maintenance is not covered by the product warranty.

Transportation

- LED lights should be shipped in sturdy packaging to prevent damage during transit.
- Avoid extreme hot or cold temperatures when transporting.
- Handle products carefully to prevent dropping or impacts.

Storage

- Store in a dry, room-temperature environment away from moisture/humidity.
- Avoid storing in very hot or freezing areas for extended periods.
- Packaging should protect against dust/debris when not in use.

Power Supply/Driver Space

- Allow several inches of clearance around any external power supply units or LED drivers for ventilation and heat dissipation.

Light Head Clearances

- Provide at least 6-12 inches of clearance from any walls or surfaces to avoid heating issues.
- Ideal spacing between multiple LED light heads depends on their beam angles, but 2-4 feet is typical to prevent overlapping hot spots.

Set/Subject Spacing

- The minimum distance from the LED front to a subject depends on the beam angle and intensity of the particular model.
- For broad sources, 3-6 feet is common, while narrow beam LED lights may need 6-10 feet of working distance.

Cable Management

- Leave enough space to neatly arrange power and data cables without pinching or excessive bending.



Do not stare at the operating light source

- Do not look directly at the LED source during operation. It can be harmful to the eyes and skin.
- During Installation, operation, and maintenance, be prepared for the fixture to illuminate when connected to power.



Photobiological safety

- This device emits potentially dangerous optical radiation and is identified in the category of Risk Group 1 according to EN 62471.

SAFETY INFORMATION



Disposal

- This product is supplied in compliance with European Directive 2012/19/EU – Waste Electrical and Electronic Equipment (WEEE). To preserve the environment please dispose/ recycle this product at the end of its life according to the local regulation.



The products to which this manual refers comply with

- 2014/35/EU - Safety of electrical equipment supplied at low voltage (LVD).
- 2014/30/EU - Electromagnetic Compatibility (EMC).
- 2011/65/EU - Restriction of the use of certain hazardous substances (RoHS).



The products referred to in this manual comply with

- UL 1573 + CSA C22.2 No. 166 - Stage and studio luminaires and connection strips.



FCC Compliance

- This device complies with Part 15 of the FCC Rules. Operation is subject to the following two conditions:
 1. This device may not cause harmful interference.
 2. This device must accept any interference received, including interference that may cause undesired operation.

WARRANTY

Unless otherwise stated, your product is covered by a **one-year parts and labor limited warranty**.

Fiilex guarantees, to the original buyer, that this product is to be free of defects in both workmanship and material for a period of one year from the date of shipment. This warranty extends to all products which have proved defective through normal use but excludes products that have been disassembled, modified, or misused by the buyer or any other person. This warranty is in lieu of all other warranties, and disclaims all warranties expressed or implied, including any warranty of merchantability, fitness for a particular purpose, or arising from the course of dealing between the parties or usage of trade.

Returning an item under warranty for repair

It is necessary to obtain a Return Authorization Number (RA#) from your dealer/point of purchase BEFORE any units are returned for repair. Fiilex will make the final determination as to whether or not the unit is covered by warranty. Fiilex will replace or repair to proper working condition any products that are returned under warranty. Products repaired or replaced under warranty are under warranty only for the remaining unexpired period of time of the original warranty.

Any Product unit or part returned to Fiilex must be packaged in a suitable manner to ensure the protection of such Product units or parts. The package must be clearly and prominently marked to indicate that the package contains returned Product units or parts with a Return Authorization (RA#) number. All returned product units or parts must be accompanied by a written explanation of the alleged problem or malfunction.

- DO NOT obstruct the fixture's air vents.
- DO NOT install the light fixture in damp or wet locations.
- DO NOT disassemble the light fixture. This will void the warranty.
- DO NOT look into the light source. Be cautious of the high-intensity beam.
- The luminaire should be operated by trained users only.
- Use a safety cable (not included) when rigging the light fixture overhead.
- Shields and lenses shall be changed if they have become visibly damaged.
- If damaged, the luminaire must be repaired or replaced before further use.
- Only use Fiilex approved power supply and accessories. Failure to do so may damage the fixture and will void the fixture's warranty.

1 - PACKAGING

Package contents

- 1x K10 COLOR Head & Yoke
- 1x FLXK10CLR-FRNL12
- 1x FLXK10CLR-PSU-ACJ18-TRUE1

Optional accessories

The most updated accessories list, descriptions, and information about the product can be found on the Filex webpage at www.filex.com

2 - SPECIFICATION

Field Angle	12° with lens (18°/30°/50° with optional lens accessories)
CCT Range	2000-10000K continuous tuning + magenta/green shift
CRI / TLCI	95/90 typical
Control Modes	CCT, HSI, RGBW, GEL, CCTRGBW, CCTHSI, CIExy, ICTHS, and more
Dimming	100% - 0% flicker free
Dimming Modes / Curves	Smooth, Sharp / Linear, Gamma
Light Engine	DiCon Dense Matrix LED
Power Consumption	900W max AC
BTUs/hour	3071 (BTUs/hour) max
AC Input	100 - 240V AC, 50 ~ 60Hz
DMX/RDM Port	XLR-5 in and out
Wireless Control	Integrated LumenRadio CRMX Timo Two
Weight	Fixture: 34.1lbs / 15.5kg (With Yoke)
Size (L x W x H)	23.0" x 20.3" x 12.6" / 58.3cm x 51.6cm x 31.9cm (With Yoke)
	13.6" x 14.4" x 12.6" / 34.5cm x 36.7cm x 31.9cm (Light Head Only)
Mount type	Combo (baby stud female / junior stud male)
IP Rating	IP-X5 (water-resistant)
Thermal Design	Controllable fan (OFF / SILENT / AUTO / FULL)
Operating Temperature	0 - 40°C / 32 - 104°F
Field Angle	2000-10000K continuous tuning + magenta/green shift

3 - TECHNICAL DRAWING INFORMATION

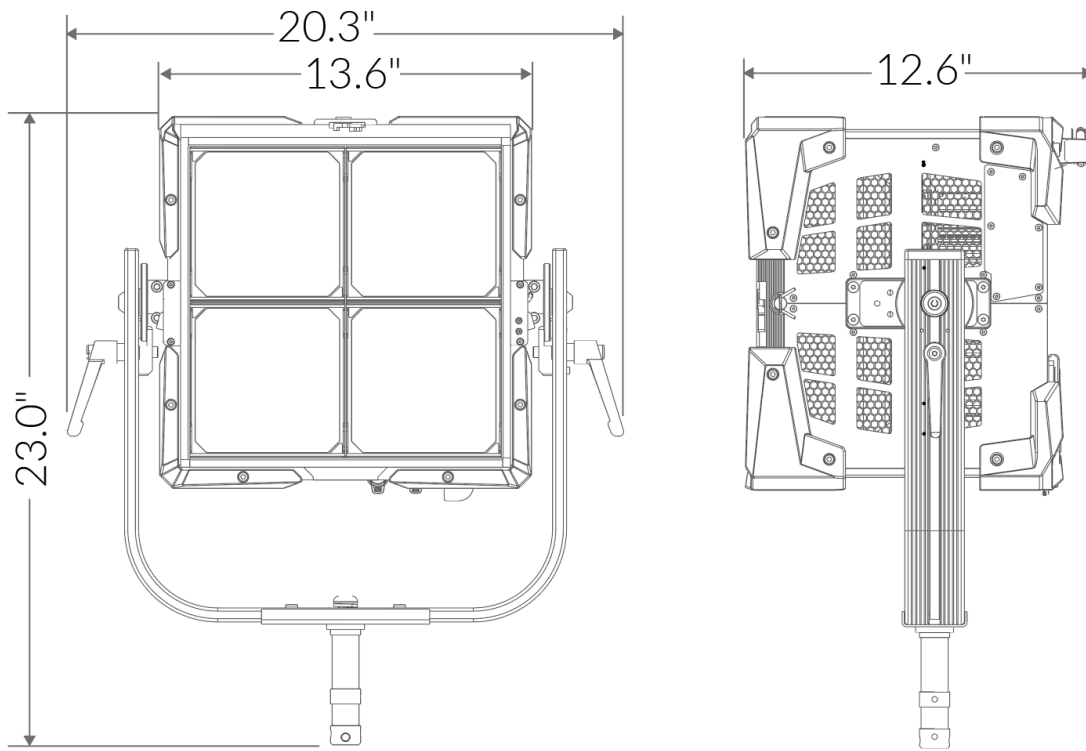

FLXK10CLR - Weight
 Fixture: 34.1lbs / 15.5kg (With Yoke)

4 - PHOTOMETRIC DATA

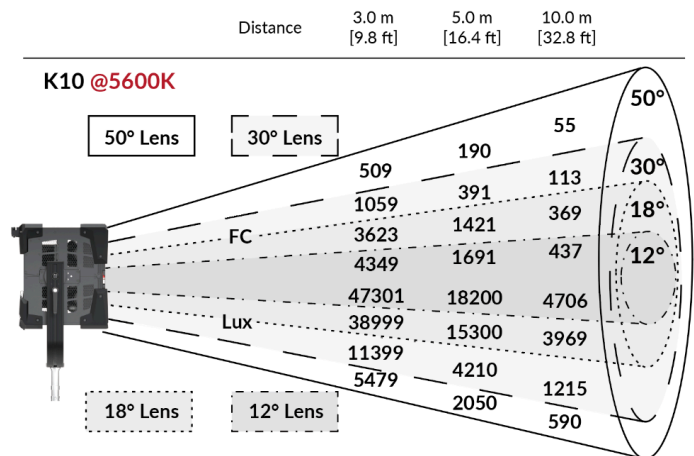
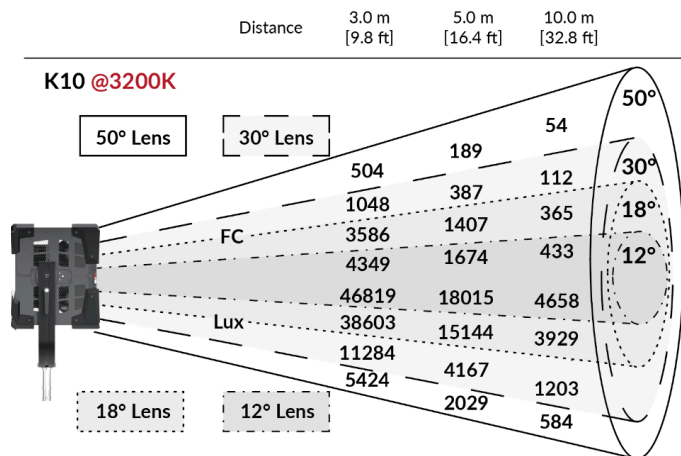

5 - BEAM PROFILE

Beam Profile of K10 COLOR

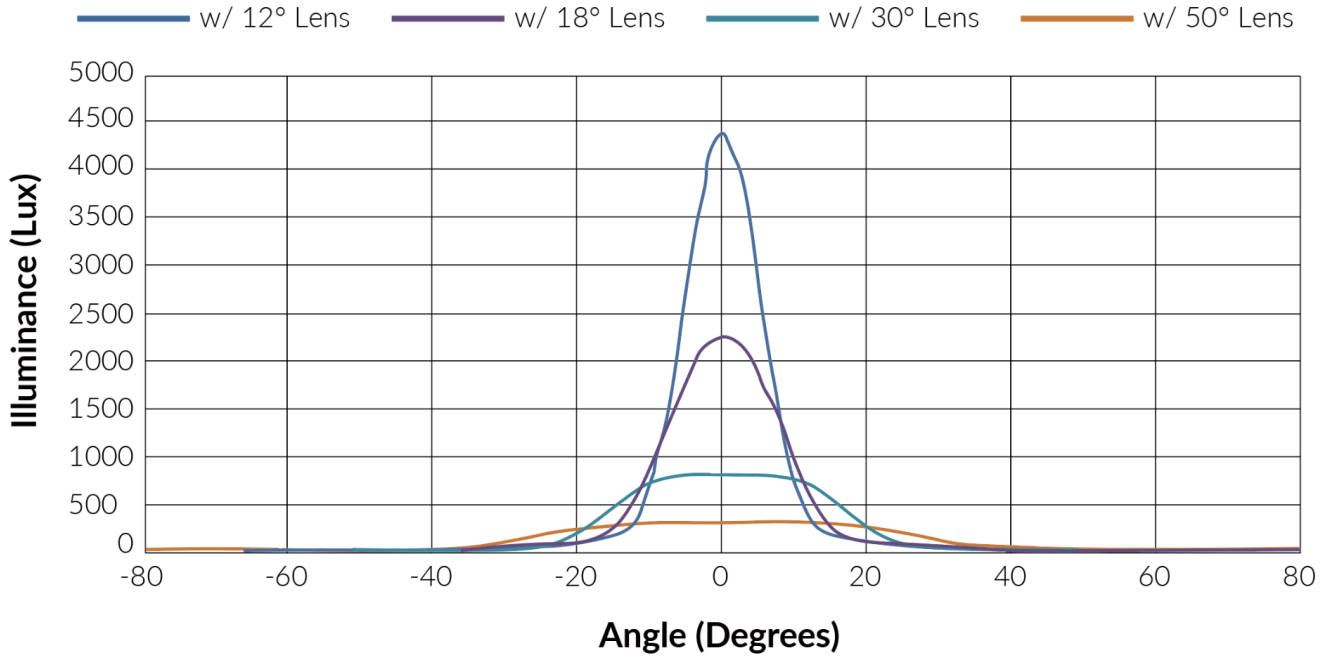

6 - INSTALLATION

Mounting

Check that the supporting structure can safely bear the weight of all installed fixtures, clamps, cables, auxiliary equipment, etc. and complies with locally applicable regulations. When suspending the fixture above ground level, secure it against failure of primary attachments by attaching a safety wire that is approved as a safety attachment for the weight of the fixture to an anchor point on the product main frame. Do not use removable parts or weak anchors for secondary attachment.

Warning! When clamping the fixture to a truss or other structure at any angle, use clamps of half coupler type. Do not use any type of clamp that does not completely encircle the structure when fastened.

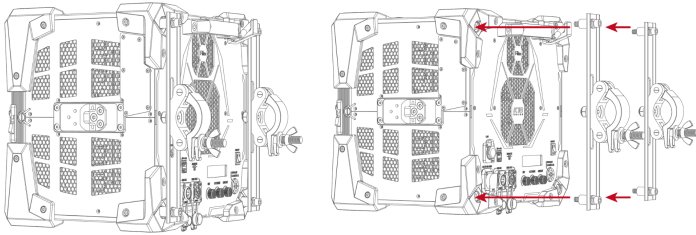

Attach Clamp

**Filex does not include a clamp with lighting products
.K10 Flush Truss Clamp (2 per fixture) available for purchase.*

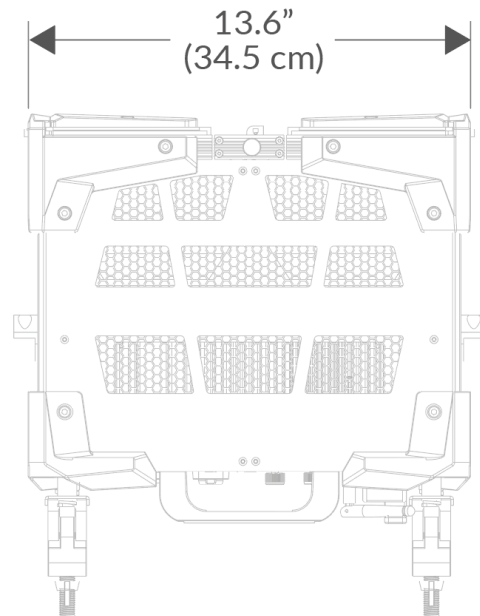
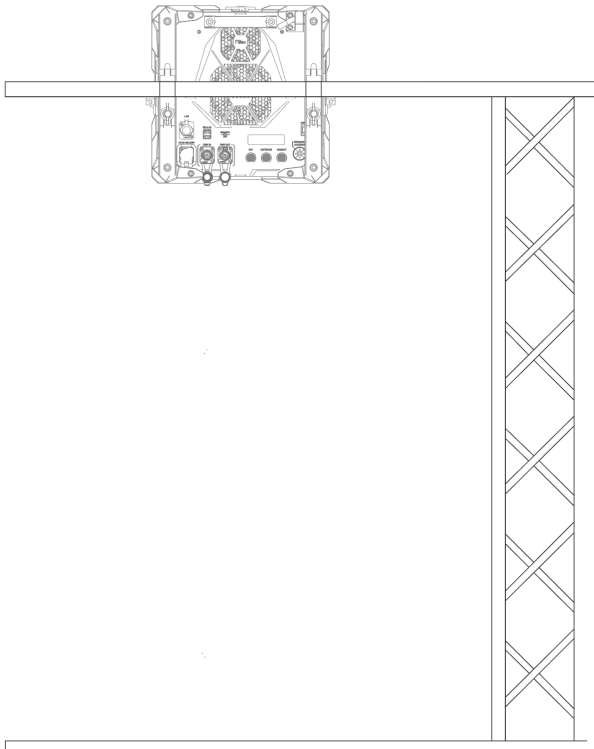

7 - CONNECTION TO AC POWER

Warning!

The max power consumption is 900W.

To protect from electric shock, the fixture must be grounded. The product is equipped with auto-switching power supply that automatically adjusts to any 50-60Hz AC power source from 100-240 Volts. If you need to install a power plug on the power cable to allow connection to power outlets, install a grounding-type plug, following the plug manufacturer's instructions. If you have any doubts about proper installation, consult a qualified electrician.

Core (EU)	Core (US)	Connection	Plug terminal marking
Brown	Black	Live	L
Blue	White	Neutral	N
Yellow+green	Green	Ground	

8 - START UP

Connect and disconnect power from the product

To apply and disconnect power to the product:

- Check that the product is installed and secured as indicated in the Safety Information, and that personal safety will not be put at risk when the fixture lights up.
- Connect the power connector into the AC input socket (100-240V AC-50/60 Hz).
- The product is then ready for its operations and can be controlled through the available input signals on board.
- To disconnect power from the product, disconnect the AC input from the socket.

9 - PRODUCT OVERVIEW

Parts Diagram

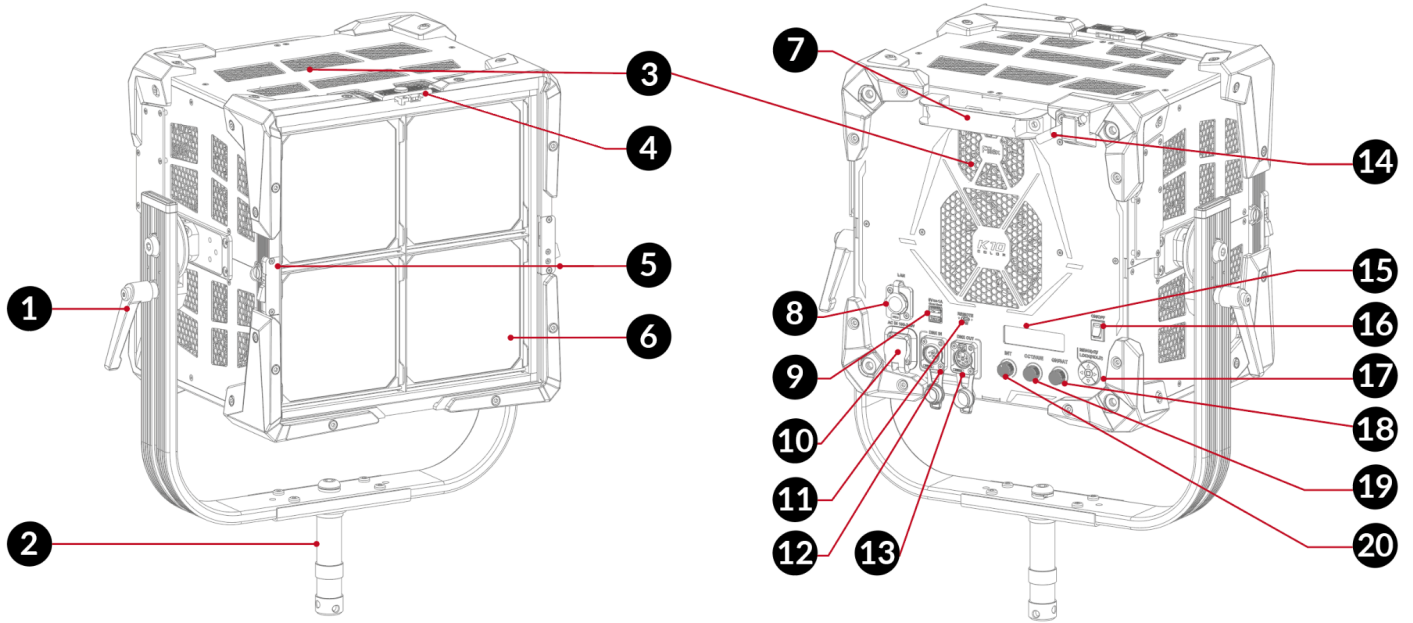

- | | | |
|-----------------------------|--|----------------------------|
| 1. Tilt Lock Lever | 8. LAN Port | 14. Antenna |
| 2. Baby/Junior Pin Receiver | 9. USB Type-A Port (5V/1A Power) | 15. OLED Panel |
| 3. Vent Holes | 10. AC Input Port (100-240V) | 16. ON/OFF Switch |
| 4. Accessory Top Lock | 11. USB Type-C Port
(For updating firmware/RPU) | 17. Navigation Pad |
| 5. Accessory Side Lock | 12. DMX Input (XLR-Male 5-pin) | 18. GN/SAT Knob |
| 6. 12deg Lens | 13. DMX Output (XLR-Female 5-pin) | 19. CCT/HUE Knob |
| 7. Handle | | 20. Intensity Control Knob |

10 - CONTROL PANEL

The product has a display and buttons to access the control panel functions.

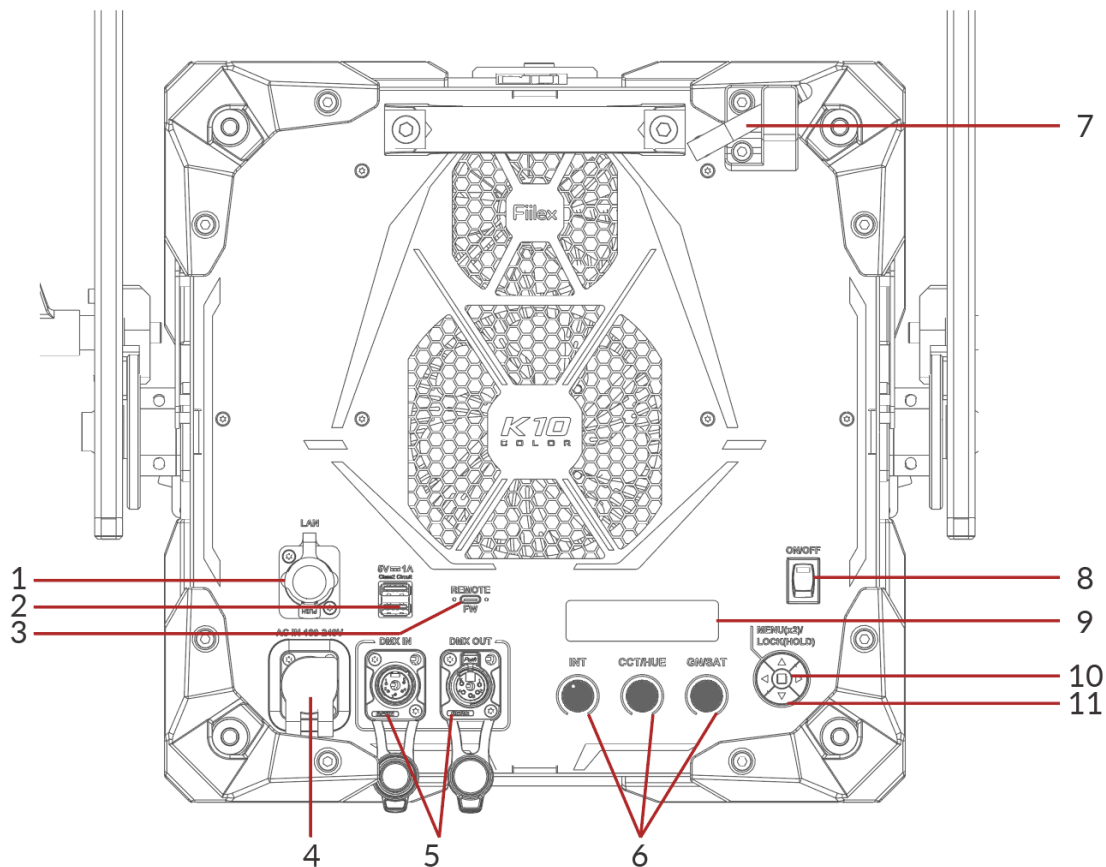









Display and buttons layout





1. LAN Port : Used to connect to a local network for smart control and monitoring
2. USB Type-A Port : 5V/1A USB power port
3. REMOTE FW Port : For firmware updates/remote patcher utility
4. AC 100-240V : 100-240V AC power input
6. Knobs : Adjustments (Parameter adjusted depends on DMX operating mode)
6. OK Button : Confirms current menu, value or option
7. Antenna : LumenRadio CRMX antenna
8. ON/OFF Button : Powers the LED engine on and off
9. OLED Panel : Used to view all menu functions
10. OK Button : Confirms current menu, value or option
11. Navigation Pad : Used to access and adjust parameters



10 - CONTROL PANEL

Knob Function

Knob								
Actions	Turn CCT/HUE Adjust	Press Quick Adjust	Turn GN/SAT Adjust	Press Quick Adjust	Turn INT Adjust	Press Up/Down Move	Press Left/Right Move	Press Confirm

Knob behavior for all modes

Input			DMX Modes														
Knob	Actions	Description	CCT EZ CCT	HSI EZ HSI	RGBW EZ RGBW	CCTHSI EZ CCTHSI	CCTRGBW EZ CCTRGBW	CIExy EZ CIExy	GEL	RGB EZ RGB	CCTxy EZ CCTxy	ICTHS EZ ICTHS	ICT RGBW EZ ICTRGBW	ICT xy EZ ICTxy	EZ 3200K	EZ 5600K	
	Turn	Adjust INT value	✓	✓	✓	✓	✓	✓	✓		✓	✓	✓	✓	✓	✓	
	Turn CCT/HUE	Adjust CCT value	✓														
		Adjust HUE value		✓													
		Quick Adjust			R/G/B/W	CCT/GN/ XFADE/ HUE/SAT	CCT/GN/ XFADE/ R/G/B/W	x/y		R/G/B	CCT/GN/ XFADE/ x/y	CCT/GN/ HUE/SAT	CCT/GN/ R/G/B/W	CCT/GN/ x/y			
	Press CCT/HUE	Quick Adjust	3200K 5600K														
		HUE value ↻ 1 Press +60°		✓													
	Turn GN/SAT	Adjust GN value	✓														
		Adjust SAT value		✓													
	Press GN/SAT	GN value ↻ 1 Press +0.25	✓														
		SAT value ↻ 1 Press +25%		✓													

Buttons		All Modes											
		Actions	Function	INT	CCT	GN	HUE	SAT	R/G/B/W	XFADE	X,Y	DMX START ADDR	IP value
Up/Down Button		Press Up/Down	Adjust Value	±1	±50	±0.01	±1	±1	±1	±1	±0.001	±1	±1
		Press Hold (1s) Up/Down		±10	±500	±0.1	±10	±10	±10	±10	±10	±0.05	±10
Center Button		Press Confirm	Switch Value	+25% ↻	3200K 5600K	+0.25 ↻	+60° ↻	+25° ↻	+25 ↻	+25 ↻	+0.2 ↻	+100 ↻	

*CCT-x,y quick switch function does not work in Gel mode.

11 - DMX CONNECTION

Connection of the DMX signal

The product has XLR-5 sockets for DMX input and output.
The default pin-out on both sockets is shown below:

DMX - INPUT
XLR-5 plug



Pin1 : GND - Shield
Pin2 : - Signal
Pin3 : + Signal
Pin4 : N/C
Pin5 : N/C

DMX - OUTPUT
XLR-5 socket



Instructions for a reliable DMX connection

Use a shielded twisted-pair cable designed for RS-485 devices: standard microphone cables cannot transmit control data reliably over long runs. 24 AWG cable are suitable for runs up to 300 meters (1000 ft). A heavier gauge cable and/or an amplifier is recommended for longer runs. To split the data link into branches, use splitter-amplifiers in the connection line.
Up to 32 devices may be connected on a single DMX run.

Daisy chaining

Connect the DMX data output from the DMX source to the product DMX input (male connector XLR-5) socket. Run the data link from the product XLR-5 output (female connector XLR-5) socket to the DMX input of the next fixture. Terminate the data line by connecting a 120 Ohm signal terminator to the last fixture. If a splitter is used, terminate each branch of the link.
DMX connection employs standard XLR-5 connectors. Use shielded pair-twisted cables with 120 Ohm impedance and low capacity.

The following diagram shows the connection diagram:

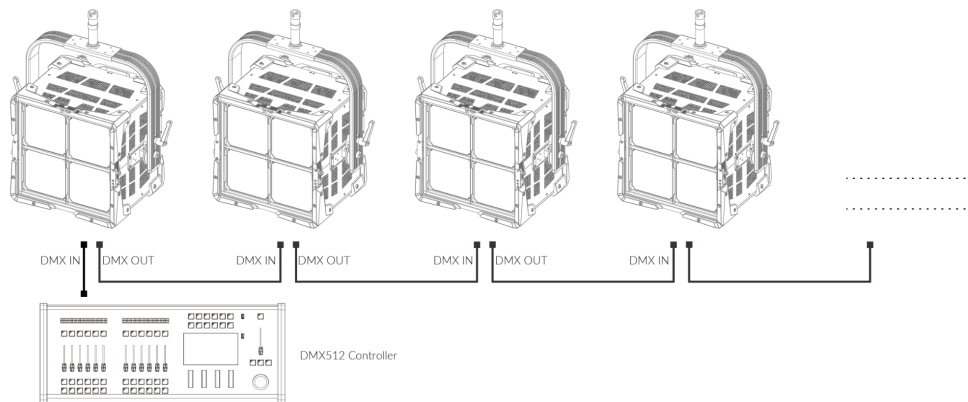

11 - DMX CONNECTION

DMX termination

The termination is prepared by soldering a 120 Ohm 1/4 W resistor between pins 2 and 3 of the male XLR-5 connector, as shown in figure.

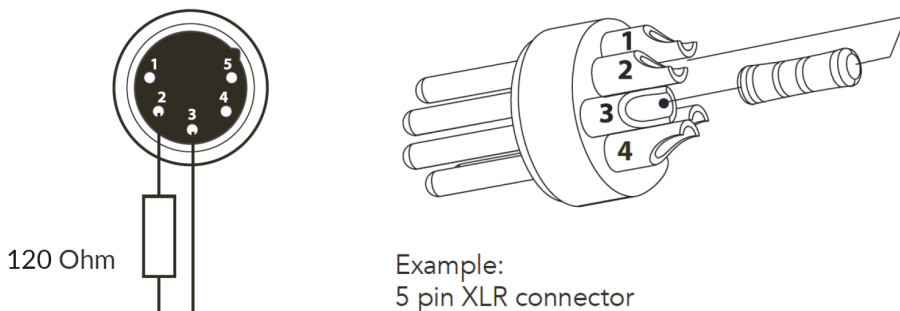

X control circuit is not isolated.

- Cumulative leakage current on the DMX control circuit is less than 3.5 mA.

DMX addressing

In order to start controlling the product via DMX, the first step is to select a DMX address, also known as the start channel. This is the first channel used to receive instructions from a DMX controller. If you wish to control the product individually, it is necessary to assign a different starting address channel to each fixture.

The number of channels occupied from the product depends on the DMX mode selected, so always verify the DMX Mode in the MENU before starting addressing.

If you assign two fixtures the same address, they will execute the same behavior. Selecting the same address to multiple fixtures can be useful for diagnostic purposes and symmetrical control.

DMX addressing is limited to make it impossible to set the DMX address so high that you are left without enough control channels for the product. When addressing DMX fixtures, ensure that the addresses are set such that the fixture footprints do not overlap. Overlapping DMX footprints will cause fixtures to exhibit unintended behavior.

To set the fixture's DMX address:

1. Press center button to enter main menu.
2. Navigate to right, reach the "DMX ADDR" menu, then select the DMX ADDRESS settings.
3. Select the address from 1 to 512 using the navigation UP/DOWN and confirm by pressing the center button.
4. Double click the center button to return to the main page.

12 - MENU STRUCTURE

Menu

- * Double click center button to return to the upper level.
- * Enter the current mode function of the Dashboard by pressing the center button.
- * Please refer to the Dashboard section for detailed flow of each function.

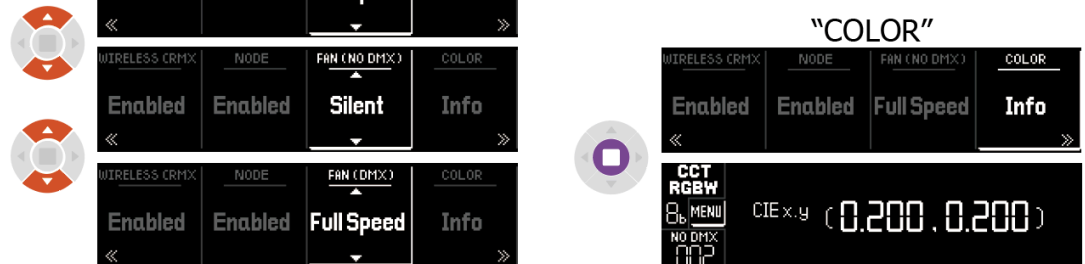
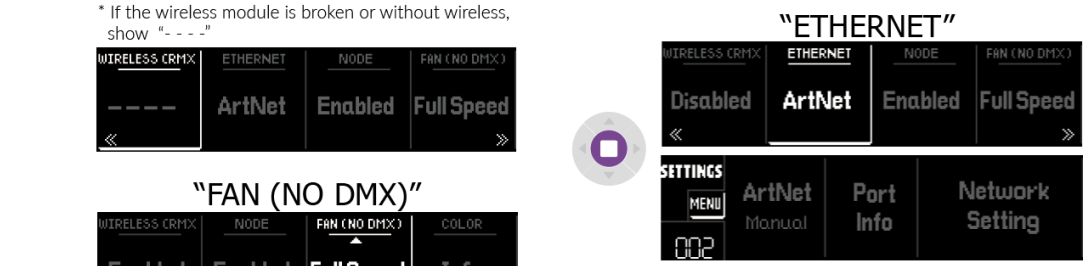
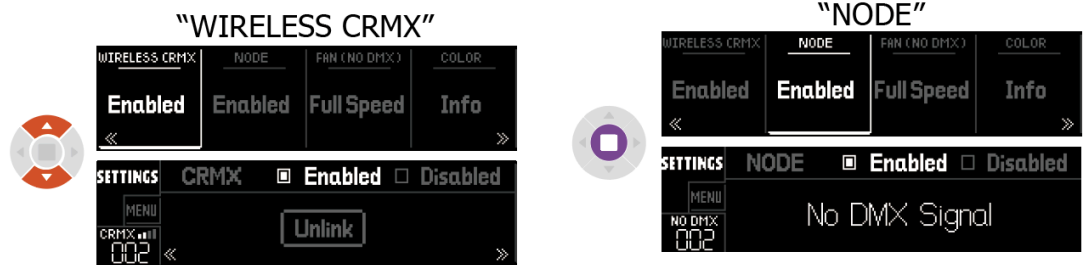
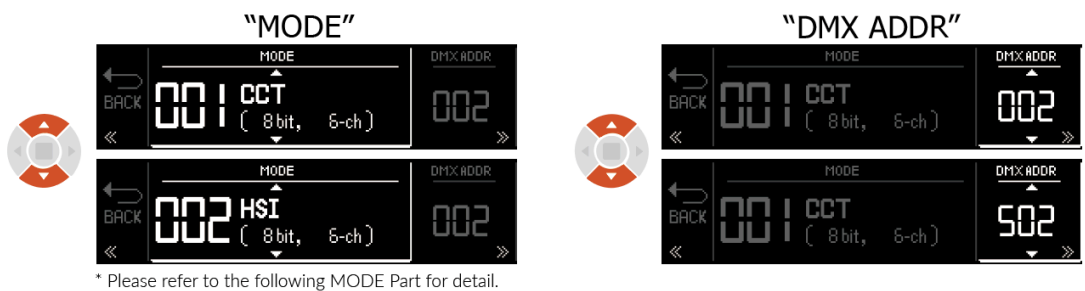
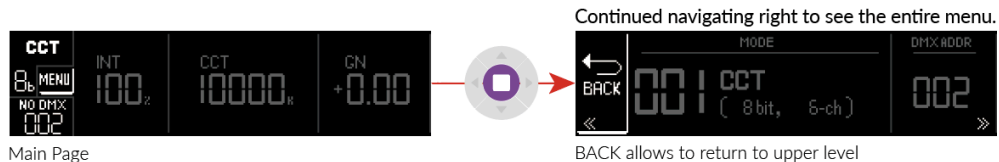

1. When DMX is connected, Fan mode will not be editable and show "Fan (DMX)".
2. When DMX is not connected, Fan mode will be editable and show "Fan (No DMX)".
3. When DMX is connected and DMX fan setting is 0-9, fan mode is still not editable and shows the internal fan setting.

12 - MENU STRUCTURE

Menu

- * Double click center button to return to the upper level.
- * Enter the current mode function of the Dashboard by pressing the center button.
- * Please refer to the Dashboard section for detailed flow of each function.

"DIMMING"

DIMMING	CURVE	WHITE POINT	SCREEN ↕
Smooth	Gamma	10000 K	Up

DIMMING	CURVE	WHITE POINT	SCREEN ↕
Sharp	Gamma	10000 K	Up

"CURVE"

DIMMING	CURVE	WHITE POINT	SCREEN ↕
Smooth	Gamma	10000 K	Up

DIMMING	CURVE	WHITE POINT	SCREEN ↕
Smooth	Linear	10000 K	Up

"WHITE POINT"

DIMMING	CURVE	WHITE POINT	SCREEN ↕
Smooth	Gamma	10000 K	Up

DIMMING	CURVE	WHITE POINT	SCREEN ↕
Smooth	Gamma	6500 K	Up

* White point : 2000k ~ 10000k

"SCREEN"

DIMMING	CURVE	WHITE POINT	SCREEN ↕
Smooth	Gamma	10000 K	Up

DIMMING	CURVE	WHITE POINT	SCREEN ↕
Smooth	Gamma	10000 K	Down

"FIXTURE"

SAVE	FIXTURE	FACTORY
Preset	Info	Reset

INFO	SN	L7X X G00000
MENU	Fw CB	v1.9.A DB v1.9.A
NO DMX	002	CAL. v1.0.A

INFO	CRMX Fw	0.0.0.0
MENU	Link Status	Notlinked Quality 100%
NO DMX	002	DMX Signal Available

INFO	Array	40°C	CB	40°C
MENU	DB	40°C	Fan	1500 rpm
NO DMX	002			

"SAVE"

SAVE	FIXTURE	FACTORY
Preset	Info	Reset

↩	
Preset A	
Preset B	

↩	
Preset A	
Preset B	

Settings Saved to Preset A

"FACTORY"

SAVE	FIXTURE	FACTORY
Preset	Info	Reset

Erase All Previous Settings?

YES	NO
-----	----

Resetting...

CCT	INT	CCT	GN
8	0.0%	10000 K	+0.00
MENU			
NO DMX	001		

13 - DMX MAPPING

The product can communicate using RDM (Remote Device Management) protocol over a DMX512 Network.

RDM is a bi-directional communications protocol for use in DMX512 control systems. RDM is the open standard for DMX512 device configuration and status monitoring.

RDM protocol allows data packets to be inserted into a DMX512 data stream without affecting existing non-RDM equipment. It allows a console or dedicated RDM controller to send commands to and receive messages from specific fixtures.

The PIDs in the following tables are supported in the product.

Notes

- * HSI, RGBW and RGB modes are based on user adjustable white point of 6500K. For instance, if a white point of 6500K is selected in HSI mode, when "Saturation" = 0%, the fixture outputs 6500K white.
- ** CCTHSI, CCTRGBW, ICTHS, and ICTRGBW modes, the white point is determined and can be adjusted by the "CCT" and "Green Adjust" parameters. This applies at any "Crossfade" value in CCTHSI and CCTRGBW modes. The following scenarios illustrate how white point is determined by the "CCT" parameter, given all other parameters being the same.

Scenario 1: In CCTRGBW modes, the following 4 settings produce the 3200K white. Notice that the white remains the same regardless of the "Crossfade" parameter.

- 1) CCT=3200K, Xfade=0%
- 2) CCT=3200K, Xfade=100%, W=100%
- 3) CCT=3200K, Xfade=100%, RGB=100%
- 4) CCT=3200K, Xfade=100%, RGBW=100%

Scenario 2: In CCTHSI modes, the following settings produce the 2800K to 5600K white respectively.

Notice that "CCT" is the only differentiating parameter, even when "Crossfade" = 100%

(2800K white) CCT=2800K, Xfade=100%, Sat=0%

(5600K white) CCT=5600K, Xfade=100%, Sat=0%

Scenario 3: In ICTRGBW modes, the following settings produce 3200K and 6500K white respectively.

Notice that the "CCT" is the only differentiating parameter

(3200K output) CCT=3200K, RGBW=100%

(6500K output) CCT=6500K, RGBW=100%

- *** In CCTxy and ICTxy modes, the "CCT" and "Green Adjust" parameters allow slight adjustment of the color temperature and tint for the selected "CIEx" and "CIEy" coordinates. To produce an output true to the CIEx and CIEy coordinates, set "CCT" = 6500K and "Green Adjust" = 0.00

13 - DMX MAPPING

K10 Control Table

Control The Control Channel consolidates extraneous parameters in all non-EZ modes	
DMX Value	Parameter
0 - 9	Keep current settings. No change
10 - 19	*Motor Enable (default) (20 packets)
20 - 29	*Motor Disable (20 packets)
30 - 39	*Motor speed slow (20 packets)
40 - 49	*Motor speed fast (default) (20 packets)
50 - 59	*Step Motor position calibration (40 packets) (Moto-Q3 Only)
60 - 69	Reserved TBD
70 - 79	Screen Flip Up (default) (20 packets)
80 - 89	Screen Flip Down (20 packets)
90 - 99	Reserved TBD
100 - 109	*seq_px_dim Enable (20 packets)
110 - 119	*seq_px_dim Disable (default) (20 packets)
120 - 129	Intensity Curve Gamma (default) (20 packets)
130 - 139	Intensity Curve Linear (20 packets)
140 - 149	Dimming Smooth (default) (20 packets)
150 - 159	Dimming Sharp (20 packets)
160 - 169	White point 6500K (default) (20 packets)
170 - 179	White point 5600K (20 packets)
180 - 189	White point 3200K (20 packets)
190 - 199	Reserved TBD
200 - 209	Fan Silent (20 packets)
210 - 219	Fan Auto (default) (20 packets) (Fixture auto adjusts)
220 - 229	Fan Full (20 packets)
230 - 239	Fan Off (20 packets)
240 - 249	Reserved TBD
250 - 255	Reserved TBD

13 - DMX MAPPING

DMX Modes

Standard Modes

Mode	8-bit (DMX Footprint)	16-bit (DMX Footprint)	Page
CCT	Mode 401 (6)	Mode 409 (9)	27
HSI*	Mode 402 (6)	Mode 410 (9)	28
RGBW *	Mode 403 (8)	Mode 411 (13)	29
CIExy	Mode 406 (6)	Mode 414 (9)	32
GEL	Mode 407 (6)	Mode 415 (7)	33
RGB *	Mode 440 (6)	Mode 445 (9)	39

CCT Modes

CCT modes allow white point adjustment using the “CCT” and “Green Adjust” parameters.

CCTHSI *	Mode 404 (9)	Mode 412 (15)	30
CCTRGBW **	Mode 405 (11)	Mode 413 (19)	31
CCTxy ***	Mode 441 (9)	Mode 446 (15)	40

ICT Modes

ICT modes allow white point adjustment like CCT+ modes, but without a “Crossfade” parameter.

ICTHS **	Mode 442 (8)	Mode 447 (13)	41
ICTRGBW **	Mode 443 (10)	Mode 448 (17)	42
ICTxy ***	Mode 444 (8)	Mode 449 (13)	43

13 - DMX MAPPING

DMX Modes

EZ Modes

EZ modes do not include “Fan Setting”, “Dimming Setting”, or “Strobe Frequency” parameters, shortening the DMX footprint.

EZ CCT	Mode 450 (3)	Mode 463 (6)	44
EZ HSI *	Mode 451 (3)	Mode 464 (6)	44
EZ RGBW *	Mode 452 (5)	Mode 465 (10)	44
EZ CIExy	Mode 455 (3)	Mode 468 (6)	46
EZ CCTHSI **	Mode 453 (6)	Mode 466 (12)	45
EZ CCTRGBW **	Mode 454 (8)	Mode 467 (16)	45
EZ CCTxy ***	Mode 457 (6)	Mode 470 (12)	46
EZ ICTHS **	Mode 458 (5)	Mode 471 (10)	47
EZ ICTRGBW **	Mode 459 (7)	Mode 472 (14)	47
EZ ICTxy ***	Mode 460 (5)	Mode 473 (10)	48
EZ RGB *	Mode 456 (3)	Mode 469 (6)	46
EZ 3200K	Mode 461 (1)	Mode 474 (2)	48
EZ 5600K	Mode 462 (1)	Mode 475 (2)	48

ALL Modes

Mode	8-bit (DMX Footprint)	16-bit (DMX Footprint)	Page
ALL MODES	Mode 476 (12)	Mode 477 (20)	49

K10 COLOR / K40 COLOR Only (DMX Control Only)

PXL4 Modes

Mode	8-bit (DMX Footprint)	16-bit (DMX Footprint)	Page
PXL4 CIExy	Mode 419 (15)	Mode 422 (27)	38
PXL4 CCTHSI **	Mode 417 (27)	Mode 420 (51)	34
PXL4 CCTRGBW **	Mode 418 (35)	Mode 421 (67)	36
PXL4 CCTxy ***	Mode 480 (27)	Mode 484 (51)	57
PXL4 ICTHS **	Mode 481 (23)	Mode 485 (43)	59
PXL4 ICTRGBW **	Mode 482 (31)	Mode 486 (59)	61
PXL4 ICTxy ***	Mode 483 (23)	Mode 487 (43)	63
PXL4 EZ CCT	Mode 488 (12)	Mode 492 (24)	65
PXL4 EZ HSI *	Mode 489 (12)	Mode 493 (24)	66

PXL4 EZ RGBW *	Mode 490 (20)	Mode 494 (40)	67
PXL4 EZ RGB *	Mode 491 (12)	Mode 495 (24)	68

13 - DMX MAPPING

K10 Control Table

Control The Control Channel consolidates extraneous parameters in all non-EZ modes	
DMX Value	Parameter
0 - 9	Keep current settings. No change
10 - 19	*Motor Enable (default) (20 packets)
20 - 29	*Motor Disable (20 packets)
30 - 39	*Motor speed slow (20 packets)
40 - 49	*Motor speed fast (default) (20 packets)
50 - 59	*Step Motor position calibration (40 packets) (Moto-Q3 Only)
60 - 69	Reserved TBD
70 - 79	Screen Flip Up (default) (20 packets)
80 - 89	Screen Flip Down (20 packets)
90 - 99	Reserved TBD
100 - 109	*seq_px_dim Enable (20 packets)
110 - 119	*seq_px_dim Disable (default) (20 packets)
120 - 129	Intensity Curve Gamma (default) (20 packets)
130 - 139	Intensity Curve Linear (20 packets)
140 - 149	Dimming Smooth (default) (20 packets)
150 - 159	Dimming Sharp (20 packets)
160 - 169	White point 6500K (default) (20 packets)
170 - 179	White point 5600K (20 packets)
180 - 189	White point 3200K (20 packets)
190 - 199	Reserved TBD
200 - 209	Fan Silent (20 packets)
210 - 219	Fan Auto (default) (20 packets) (Fixture auto adjusts)
220 - 229	Fan Full (20 packets)
230 - 239	Fan Off (20 packets)
240 - 249	Reserved TBD
250 - 255	Reserved TBD

13 - DMX MAPPING

Mode 401 (8-bit) / Mode 409 (16-bit) : CCT					
8-bit DMX	16-bit DMX	Function	8-bit/16-bit Value		Range
1	1-2	Master Intensity	0 - 255	0 - 65,535	0% - 100%
2	3-4	CCT	0 - 255	0 - 65,535	2000K - 10000K
3	5-6	Green Adjust	0 - 9 10 - 255	0 - 9 10 - 65,535	Neutral (0) Full magenta ~ Full green (-1.0 ~ +1.0)
4	7	Strobe Frequency	0 - 9 10 - 255		Strobe off 1Hz - 25Hz
5	8	Control	See control table		
6	9	Reserved	TBD		

13 - DMX MAPPING

Mode 402 (8-bit) / Mode 410 (16-bit) : HSI					
8-bit DMX	16-bit DMX	Function	8-bit/16-bit Value		Range
1	1-2	Master Intensity	0 - 255	0 - 65,535	0% - 100%
2	3-4	Hue	0 - 255	0 - 65,535	0° - 360°
3	5-6	Saturation	0 - 255	0 - 65,535	0% - 100%
4	7	Strobe Frequency	0 - 9 10 - 255		Strobe off 1Hz - 25Hz
5	8	Control	See control table		
6	9	Reserved	TBD		

13 - DMX MAPPING

Mode 403 (8-bit) / Mode 411 (16-bit) : RGBW					
8-bit DMX	16-bit DMX	Function	8-bit/16-bit Value		Range
1	1-2	Master Intensity	0 - 255	0 - 65,535	0% - 100%
2	3-4	Intensity Red	0 - 255	0 - 65,535	0% - 100%
3	5-6	Intensity Green	0 - 255	0 - 65,535	0% - 100%
4	7-8	Intensity Blue	0 - 255	0 - 65,535	0% - 100%
5	9-10	Intensity White	0 - 255	0 - 65,535	0% - 100%
6	11	Strobe Frequency	0 - 9 10 - 255		Strobe off 1Hz - 25Hz
7	12	Control	See control table		
8	13	Reserved	TBD		

13 - DMX MAPPING

Mode 404 (8-bit) / Mode 412 (16-bit) : CCTHSI					
8-bit DMX	16-bit DMX	Function	8-bit/16-bit Value		Range
1	1-2	Master Intensity	0 - 255	0 - 65,535	0% - 100%
2	3-4	CCT	0 - 255	0 - 65,535	2000K - 10000K
3	5-6	Green Adjust	0 - 9 10 - 255	0 - 9 10 - 65,535	Neutral (0) Full magenta ~ Full green (-1.0 ~ +1.0)
4	7-8	Crossfade	0 - 255	0 - 65,535	0% - 100%
5	9-10	Hue	0 - 255	0 - 65,535	0° - 360°
6	11-12	Saturation	0 - 255	0 - 65,535	0% - 100%
7	13	Strobe Frequency	0 - 9 10 - 255		Strobe off 1Hz - 25Hz
8	14	Control	See control table		
9	15	Reserved	TBD		

13 - DMX MAPPING

Mode 405 (8-bit) / Mode 413 (16-bit) : CCTRGBW					
8-bit DMX	16-bit DMX	Function	8-bit/16-bit Value		Range
1	1-2	Master Intensity	0 - 255	0 - 65,535	0% - 100%
2	3-4	CCT	0 - 255	0 - 65,535	2000K - 10000K
3	5-6	Green Adjust	0 - 9 10 - 255	0 - 9 10 - 65,535	Neutral (0) Full magenta ~ Full green (-1.0 ~ +1.0)
4	7-8	Crossfade	0 - 255	0 - 65,535	0% - 100%
5	9-10	Intensity Red	0 - 255	0 - 65,535	0% - 100%
6	11-12	Intensity Green	0 - 255	0 - 65,535	0% - 100%
7	13-14	Intensity Blue	0 - 255	0 - 65,535	0% - 100%
8	15-16	Intensity White	0 - 255	0 - 65,535	0% - 100%
9	17	Strobe Frequency	0 - 9 10 - 255		Strobe off 1Hz - 25Hz
10	18	Control	See control table		
11	19	Reserved	TBD		

13 - DMX MAPPING

Mode 406 (8-bit) / Mode 414 (16-bit) : CIExy					
8-bit DMX	16-bit DMX	Function	8-bit/16-bit Value		Range
1	1-2	Master Intensity	0 - 255	0 - 65,535	0% - 100%
2	3-4	x	0 - 255	0 - 65,535	0.0 - 0.8
3	5-6	y	0 - 255	0 - 65,535	0.0 - 0.8
4	7	Strobe Frequency	0 - 9 10 - 255		Strobe off 1Hz - 25Hz
5	8	Control	See control table		
6	9	Reserved	TBD		

13 - DMX MAPPING

Mode 407 (8-bit) / Mode 415 (16-bit) : GEL

8-bit DMX	16-bit DMX	Function	8-bit/16-bit Value		Range
1	1-2	Master Intensity	0 - 255	0 - 65,535	0% - 100%
2	3	Gel Filter	0 - 9 10 - 19 20 - 29 30 - 39 40 - 49 50 - 59 60 - 69 70 - 79 80 - 89 90 - 99 100 - 109 110 - 119 120 - 129 130 - 139 140 - 149 150 - 159 160 - 169 170 - 179 180 - 189 190 - 199 200 - 209 210 - 255		None Bastard Amber Straw Light Amber Light Flame Golden Amber Light Red No Color Pink Middle Rose Light Rose Purple Surprise Pink No Color Blue Daylight Blue Primary Blue Moss Green Blue Green Gel 1 Gel 2 Gel 3 Gel 4 Gel 5 Reserved
3	4	CCT (Disabled for Gel 1-5)	0 - 99 100 - 255		3200K 6500K
4	5	Strobe Frequency	0 - 9 10 - 255		Strobe off 1Hz - 25Hz
5	6	Control	See control table		
6	7	Reserved	TBD		

13 - DMX MAPPING

Mode 417 (8-bit) / Mode 420 (16-bit) : PXL4 CCTHSI						
8-bit DMX	16-bit DMX	Pixel	Function	8-bit/16-bit Value		Range
1	1-2	1	Master Intensity	0 - 255	0 - 65,535	0% - 100%
2	3-4		CCT	0 - 255	0 - 65,535	2000K - 10000K
3	5-6		Green Adjust	0 - 9 10 - 255	0 - 9 10 - 65,535	Neutral (0) Full magenta ~ Full green (-1.0 ~ +1.0)
4	7-8		Crossfade	0 - 255	0 - 65,535	0% - 100%
5	9-10		Hue	0 - 255	0 - 65,535	0° - 360°
6	11-12		Saturation	0 - 255	0 - 65,535	0% - 100%
7	13-14	2	Master Intensity	0 - 255	0 - 65,535	0% - 100%
8	15-16		CCT	0 - 255	0 - 65,535	2000K - 10000K
9	17-18		Green Adjust	0 - 9 10 - 255	0 - 9 10 - 65,535	Neutral (0) Full magenta ~ Full green (-1.0 ~ +1.0)
10	19-20		Crossfade	0 - 255	0 - 65,535	0% - 100%
11	21-22		Hue	0 - 255	0 - 65,535	0° - 360°
12	23-24		Saturation	0 - 255	0 - 65,535	0% - 100%
13	25-26	3	Master Intensity	0 - 255	0 - 65,535	0% - 100%
14	27-28		CCT	0 - 255	0 - 65,535	2000K - 10000K
15	29-30		Green Adjust	0 - 9 10 - 255	0 - 9 10 - 65,535	Neutral (0) Full magenta ~ Full green (-1.0 ~ +1.0)
16	31-32		Crossfade	0 - 255	0 - 65,535	0% - 100%
17	33-34		Hue	0 - 255	0 - 65,535	0° - 360°
18	35-36		Saturation	0 - 255	0 - 65,535	0% - 100%
19	37-38	4	Master Intensity	0 - 255	0 - 65,535	0% - 100%
20	39-40		CCT	0 - 255	0 - 65,535	2000K - 10000K

21	41-42		Green Adjust	0 - 9 10 - 255	0 - 9 10 - 65, 535	Neutral (0) Full magenta ~ Full green (-1.0 ~ +1.0)
22	43-44		Crossfade	0 - 255	0 - 65, 535	0% - 100%
23	45-46		Hue	0 - 255	0 - 65, 535	0° - 360°
24	47-48		Saturation	0 - 255	0 - 65, 535	0% - 100%
25	49		Strobe Frequency	0 - 9 10 - 255		Strobe off 1Hz - 25Hz
26	50		Control	See control table		
27	51		Reserved	TBD		

13 - DMX MAPPING

Mode 418 (8-bit) / Mode 421 (16-bit) : PXL4 CCTRGBW

8-bit DMX	16-bit DMX	Pixel	Function	8-bit/16-bit Value		Range
1	1-2	1	Master Intensity	0 - 255	0 - 65,535	0% - 100%
2	3-4		CCT	0 - 255	0 - 65,535	2000K - 10000K
3	5-6		Green Adjust	0 - 9 10 - 255	0 - 9 10 - 65,535	Neutral (0) Full magenta ~ Full green (-1.0 ~ +1.0)
4	7-8		Crossfade	0 - 255	0 - 65,535	0% - 100%
5	9-10		Intensity Red	0 - 255	0 - 65,535	0% - 100%
6	11-12		Intensity Green	0 - 255	0 - 65,535	0% - 100%
7	13-14		Intensity Blue	0 - 255	0 - 65,535	0% - 100%
8	15-16		Intensity White	0 - 255	0 - 65,535	0% - 100%
9	17-18	2	Master Intensity	0 - 255	0 - 65,535	0% - 100%
10	19-20		CCT	0 - 255	0 - 65,535	2000K - 10000K
11	21-22		Green Adjust	0 - 9 10 - 255	0 - 9 10 - 65,535	Neutral (0) Full magenta ~ Full green (-1.0 ~ +1.0)
12	23-24		Crossfade	0 - 255	0 - 65,535	0% - 100%
13	25-26		Intensity Red	0 - 255	0 - 65,535	0% - 100%
14	27-28		Intensity Green	0 - 255	0 - 65,535	0% - 100%
15	29-30		Intensity Blue	0 - 255	0 - 65,535	0% - 100%
16	31-32		Intensity White	0 - 255	0 - 65,535	0% - 100%
17	33-34	3	Master Intensity	0 - 255	0 - 65,535	0% - 100%
18	35-36		CCT	0 - 255	0 - 65,535	2000K - 10000K
19	37-38		Green Adjust	0 - 9 10 - 255	0 - 9 10 - 65,535	Neutral (0) Full magenta ~ Full green (-1.0 ~ +1.0)
20	39-40		Crossfade	0 - 255	0 - 65,535	0% - 100%
21	41-42		Intensity Red	0 - 255	0 - 65,535	0% - 100%
22	43-44		Intensity Green	0 - 255	0 - 65,535	0% - 100%

23	45-46	4	Intensity Blue	0 - 255	0 - 65, 535	0% - 100%
24	47-48		Intensity White	0 - 255	0 - 65, 535	0% - 100%
25	49-50		Master Intensity	0 - 255	0 - 65, 535	0% - 100%
26	51-52		CCT	0 - 255	0 - 65, 535	2000K - 10000K
27	53-54		Green Adjust	0 - 9 10 - 255	0 - 9 10 - 65, 535	Neutral (0) Full magenta ~ Full green (-1.0 ~ +1.0)
28	55-56		Crossfade	0 - 255	0 - 65, 535	0% - 100%
29	57-58		Intensity Red	0 - 255	0 - 65, 535	0% - 100%
30	59-60		Intensity Green	0 - 255	0 - 65, 535	0% - 100%
31	61-62		Intensity Blue	0 - 255	0 - 65, 535	0% - 100%
32	63-64		Intensity White	0 - 255	0 - 65, 535	0% - 100%
33	65		Strobe Frequency	0 - 9 10 - 255		Strobe off 1Hz - 25Hz
34	66		Control	See control table		
35	67	Reserved	TBD			

13 - DMX MAPPING

Mode 419 (8-bit) / Mode 422 (16-bit) : PXL4 CIE _{xy}						
8-bit DMX	16-bit DMX	Pixel	Function	8-bit/16-bit Value		Range
1	1-2	1	Master Intensity	0 - 255	0 - 65,535	0% - 100%
2	3-4		x	0 - 255	0 - 65,535	0.0 - 0.8
3	5-6		y	0 - 255	0 - 65,535	0.0 - 0.8
4	7-8	2	Master Intensity	0 - 255	0 - 65,535	0% - 100%
5	9-10		x	0 - 255	0 - 65,535	0.0 - 0.8
6	11-12		y	0 - 255	0 - 65,535	0.0 - 0.8
7	13-14	3	Master Intensity	0 - 255	0 - 65,535	0% - 100%
8	15-16		x	0 - 255	0 - 65,535	0.0 - 0.8
9	17-18		y	0 - 255	0 - 65,535	0.0 - 0.8
10	19-20	4	Master Intensity	0 - 255	0 - 65,535	0% - 100%
11	21-22		x	0 - 255	0 - 65,535	0.0 - 0.8
12	23-24		y	0 - 255	0 - 65,535	0.0 - 0.8
13	25		Strobe Frequency	0 - 9 10 - 255		Strobe off 1Hz - 25Hz
14	26		Control	See control table		
15	27		Reserved	TBD		

13 - DMX MAPPING

Mode 440 (8-bit) / Mode 445 (16-bit) : RGB					
8-bit DMX	16-bit DMX	Function	8-bit/16-bit Value		Range
1	1-2	Intensity Red	0 - 255	0 - 65,535	0% - 100%
2	3-4	Intensity Green	0 - 255	0 - 65,535	0% - 100%
3	5-6	Intensity Blue	0 - 255	0 - 65,535	0% - 100%
4	7	Strobe Frequency	0 - 9 10 - 255		Strobe off 1Hz - 25Hz
5	8	Control	See control table		
6	9	Reserved	TBD		

13 - DMX MAPPING

Mode 441 (8-bit) / Mode 446 (16-bit) : CCTxy					
8-bit DMX	16-bit DMX	Function	8-bit/16-bit Value		Range
1	1-2	Master Intensity	0 - 255	0 - 65,535	0% - 100%
2	3-4	CCT	0 - 255	0 - 65,535	2000K - 10000K
3	5-6	Green Adjust	0 - 9 10 - 255	0 - 9 10 - 65,535	Neutral (0) Full magenta ~ Full green (-1.0 ~ +1.0)
4	7-8	Crossfade	0 - 255	0 - 65,535	0% - 100%
5	9-10	x	0 - 255	0 - 65,535	0.0 - 0.8
6	11-12	y	0 - 255	0 - 65,535	0.0 - 0.8
7	13	Strobe Frequency	0 - 9 10 - 255		Strobe off 1Hz - 25Hz
8	14	Control	See control table		
9	15	Reserved	TBD		

13 - DMX MAPPING

Mode 442 (8-bit) / Mode 447 (16-bit) : ICTHS					
8-bit DMX	16-bit DMX	Function	8-bit/16-bit Value		Range
1	1-2	Master Intensity	0 - 255	0 - 65,535	0% - 100%
2	3-4	CCT	0 - 255	0 - 65,535	2000K - 10000K
3	5-6	Green Adjust	0 - 9 10 - 255	0 - 9 10 - 65,535	Neutral (0) Full magenta ~ Full green (-1.0 ~ +1.0)
4	7-8	Hue	0 - 255	0 - 65,535	0° - 360°
5	9-10	Saturation	0 - 255	0 - 65,535	0% - 100%
6	11	Strobe Frequency	0 - 9 10 - 255		Strobe off 1Hz - 25Hz
7	12	Control	See control table		
8	13	Reserved	TBD		

13 - DMX MAPPING

Mode 443 (8-bit) / Mode 448 (16-bit) : ICTRGBW					
8-bit DMX	16-bit DMX	Function	8-bit/16-bit Value		Range
1	1-2	Master Intensity	0 - 255	0 - 65,535	0% - 100%
2	3-4	CCT	0 - 255	0 - 65,535	2000K - 10000K
3	5-6	Green Adjust	0 - 9 10 - 255	0 - 9 10 - 65,535	Neutral (0) Full magenta ~ Full green (-1.0 ~ +1.0)
4	7-8	Intensity Red	0 - 255	0 - 65,535	0% - 100%
5	9-10	Intensity Green	0 - 255	0 - 65,535	0% - 100%
6	11-12	Intensity Blue	0 - 255	0 - 65,535	0% - 100%
7	13-14	Intensity White	0 - 255	0 - 65,535	0% - 100%
8	15	Strobe Frequency	0 - 9 10 - 255		Strobe off 1Hz - 25Hz
9	16	Control	See control table		
10	17	Reserved	TBD		

13 - DMX MAPPING

Mode 444 (8-bit) / Mode 449 (16-bit) : ICTxy					
8-bit DMX	16-bit DMX	Function	8-bit/16-bit Value		Range
1	1-2	Master Intensity	0 - 255	0 - 65,535	0% - 100%
2	3-4	CCT	0 - 255	0 - 65,535	2000K - 10000K
3	5-6	Green Adjust	0 - 9 10 - 255	0 - 9 10 - 65,535	Neutral (0) Full magenta ~ Full green (-1.0 ~ +1.0)
4	7-8	x	0 - 255	0 - 65,535	0.0 - 0.8
5	9-10	y	0 - 255	0 - 65,535	0.0 - 0.8
6	11	Strobe Frequency	0 - 9 10 - 255		Strobe off 1Hz - 25Hz
7	12	Control	See control table		
8	13	Reserved	TBD		

13 - DMX MAPPING

Mode 450 (8-bit) / Mode 463 (16-bit) : EZ CCT					
8-bit DMX	16-bit DMX	Function	8-bit/16-bit Value		Range
1	1-2	Master Intensity	0 - 255	0 - 65,535	0% - 100%
2	3-4	CCT	0 - 255	0 - 65,535	2000K - 10000K
3	5-6	Green Adjust	0 - 9 10 - 255	0 - 9 10 - 65,535	Neutral (0) Full magenta ~ Full green (-1.0 ~ +1.0)

Mode 451 (8-bit) / Mode 464 (16-bit) : EZ HSI					
8-bit DMX	16-bit DMX	Function	8-bit/16-bit Value		Range
1	1-2	Master Intensity	0 - 255	0 - 65,535	0% - 100%
2	3-4	Hue	0 - 255	0 - 65,535	0° - 360°
3	5-6	Saturation	0 - 255	0 - 65,535	0% - 100%

Mode 452 (8-bit) / Mode 465 (16-bit) : EZ RGBW					
8-bit DMX	16-bit DMX	Function	8-bit/16-bit Value		Range
1	1-2	Master Intensity	0 - 255	0 - 65,535	0% - 100%
2	3-4	Intensity Red	0 - 255	0 - 65,535	0% - 100%
3	5-6	Intensity Green	0 - 255	0 - 65,535	0% - 100%
4	7-8	Intensity Blue	0 - 255	0 - 65,535	0% - 100%
5	9-10	Intensity White	0 - 255	0 - 65,535	0% - 100%

13 - DMX MAPPING

Mode 453 (8-bit) / Mode 466 (16-bit) : EZ CCTHSI					
8-bit DMX	16-bit DMX	Function	8-bit/16-bit Value		Range
1	1-2	Master Intensity	0 - 255	0 - 65,535	0% - 100%
2	3-4	CCT	0 - 255	0 - 65,535	2000K - 10000K
3	5-6	Green Adjust	0 - 9 10 - 255	0 - 9 10 - 65,535	Neutral (0) Full magenta ~ Full green (-1.0 ~ +1.0)
4	7-8	Crossfade	0 - 255	0 - 65,535	0% - 100%
5	9-10	Hue	0 - 255	0 - 65,535	0° - 360°
6	11-12	Saturation	0 - 255	0 - 65,535	0% - 100%

Mode 454 (8-bit) / Mode 467 (16-bit) : EZ CCTRGBW					
8-bit DMX	16-bit DMX	Function	8-bit/16-bit Value		Range
1	1-2	Master Intensity	0 - 255	0 - 65,535	0% - 100%
2	3-4	CCT	0 - 255	0 - 65,535	2000K - 10000K
3	5-6	Green Adjust	0 - 9 10 - 255	0 - 9 10 - 65,535	Neutral (0) Full magenta ~ Full green (-1.0 ~ +1.0)
4	7-8	Crossfade	0 - 255	0 - 65,535	0% - 100%
5	9-10	Intensity Red	0 - 255	0 - 65,535	0% - 100%
6	11-12	Intensity Green	0 - 255	0 - 65,535	0% - 100%
7	13-14	Intensity Blue	0 - 255	0 - 65,535	0% - 100%
8	15-16	Intensity White	0 - 255	0 - 65,535	0% - 100%

13 - DMX MAPPING

Mode 455 (8-bit) / Mode 468 (16-bit) : EZ CIE_{xy}

8-bit DMX	16-bit DMX	Function	8-bit/16-bit Value		Range
1	1-2	Master Intensity	0 - 255	0 - 65,535	0% - 100%
2	3-4	x	0 - 255	0 - 65,535	0.0 - 0.8
3	5-6	y	0 - 255	0 - 65,535	0.0 - 0.8

Mode 456 (8-bit) / Mode 469 (16-bit) : EZ RGB

8-bit DMX	16-bit DMX	Function	8-bit/16-bit Value		Range
1	1-2	Intensity Red	0 - 255	0 - 65,535	0% - 100%
2	3-4	Intensity Green	0 - 255	0 - 65,535	0% - 100%
3	5-6	Intensity Blue	0 - 255	0 - 65,535	0% - 100%

Mode 457 (8-bit) / Mode 470 (16-bit) : EZ CCT_{xy}

8-bit DMX	16-bit DMX	Function	8-bit/16-bit Value		Range
1	1-2	Master Intensity	0 - 255	0 - 65,535	0% - 100%
2	3-4	CCT	0 - 255	0 - 65,535	2000K - 10000K
3	5-6	Green Adjust	0 - 9 10 - 255	0 - 9 10 - 65,535	Neutral (0) Full magenta ~ Full green (-1.0 ~ +1.0)
4	7-8	Crossfade	0 - 255	0 - 65,535	0% - 100%
5	9-10	x	0 - 255	0 - 65,535	0.0 - 0.8
6	11-12	y	0 - 255	0 - 65,535	0.0 - 0.8

13 - DMX MAPPING

Mode 458 (8-bit) / Mode 471 (16-bit) : EZ ICTHS

8-bit DMX	16-bit DMX	Function	8-bit/16-bit Value		Range
1	1-2	Master Intensity	0 - 255	0 - 65,535	0% - 100%
2	3-4	CCT	0 - 255	0 - 65,535	2000K - 10000K
3	5-6	Green Adjust	0 - 9 10 - 255	0 - 9 10 - 65,535	Neutral (0) Full magenta ~ Full green (-1.0 ~ +1.0)
4	7-8	Hue	0 - 255	0 - 65,535	0° - 360°
5	9-10	Saturation	0 - 255	0 - 65,535	0% - 100%

Mode 459 (8-bit) / Mode 472 (16-bit) : EZ ICTRGBW

8-bit DMX	16-bit DMX	Function	8-bit/16-bit Value		Range
1	1-2	Master Intensity	0 - 255	0 - 65,535	0% - 100%
2	3-4	CCT	0 - 255	0 - 65,535	2000K - 10000K
3	5-6	Green Adjust	0 - 9 10 - 255	0 - 9 10 - 65,535	Neutral (0) Full magenta ~ Full green (-1.0 ~ +1.0)
4	7-8	Intensity Red	0 - 255	0 - 65,535	0% - 100%
5	9-10	Intensity Green	0 - 255	0 - 65,535	0% - 100%
6	11-12	Intensity Blue	0 - 255	0 - 65,535	0% - 100%
7	13-14	Intensity White	0 - 255	0 - 65,535	0% - 100%

13 - DMX MAPPING

Mode 460 (8-bit) / Mode 473 (16-bit) : EZ ICTxy					
8-bit DMX	16-bit DMX	Function	8-bit/16-bit Value		Range
1	1-2	Master Intensity	0 - 255	0 - 65,535	0% - 100%
2	3-4	CCT	0 - 255	0 - 65,535	2000K - 10000K
3	5-6	Green Adjust	0 - 9 10 - 255	0 - 9 10 - 65,535	Neutral (0) Full magenta ~ Full green (-1.0 ~ +1.0)
4	7-8	x	0 - 255	0 - 65,535	0.0 - 0.8
5	9-10	y	0 - 255	0 - 65,535	0.0 - 0.8

Mode 461 (8-bit) / Mode 474 (16-bit) : EZ 3200K					
8-bit DMX	16-bit DMX	Function	8-bit/16-bit Value		Range
1	1-2	Master Intensity	0 - 255	0 - 65,535	0% - 100%

Mode 462 (8-bit) / Mode 475 (16-bit) : EZ 5600K					
8-bit DMX	16-bit DMX	Function	8-bit/16-bit Value		Range
1	1-2	Master Intensity	0 - 255	0 - 65,535	0% - 100%

13 - DMX MAPPING

Mode 476 (8-bit) / Mode 477 (16-bit) : ALL MODES					
8-bit DMX	16-bit DMX	Function	8-bit/16-bit Value		Range
1	1-2	Master Intensity	0 - 255	0 - 65,535	0% - 100%
2	3	Color Mode Selection	0 - 9 10 - 19 20 - 29 30 - 39 40 - 49 50 - 59 60 - 69 70 - 79 80 - 89 90 - 99 100 - 109 110 - 119 120 - 129 130 - 255		CCT HSI RGBW CCTHSI CCTRGBW CIExy GEL DEMO RGB CCTxy ICTHS ICTRGBW ICTxy Reserved
3	4-5	Color Parameter 1	See table below		
4	6-7	Color Parameter 2			
5	8-9	Color Parameter 3			
6	10-11	Color Parameter 4			
7	12-13	Color Parameter 5			
8	14-15	Color Parameter 6			
9	16-17	Color Parameter 7			
10	18	Strobe Frequency	0 - 9 10 - 255		Strobe off 1Hz - 25Hz
11	19	Control	See control table		
12	20	Reserved	TBD		

13 - DMX MAPPING

8-bit DMX	16-bit DMX	Function	8-bit/16-bit Value		Range
CCT					
3	4-5	CCT	0 - 255	0 - 65,535	2000K - 10000K
4	6-7	Green Adjust	0 - 9 10 - 255	0 - 9 10 - 65,535	Neutral (0) Full magenta ~ Full green (-1.0 ~ +1.0)
HSI					
3	4-5	Hue	0 - 255	0 - 65,535	0° - 360°
4	6-7	Saturation	0 - 255	0 - 65,535	0% - 100%
CIExy					
3	4-5	x	0 - 255	0 - 65,535	0.0 - 0.8
4	6-7	y	0 - 255	0 - 65,535	0.0 - 0.8
RGBW					
3	4-5	INT Red	0 - 255	0 - 65,535	0% - 100%
4	6-7	INT Green	0 - 255	0 - 65,535	0% - 100%
5	8-9	INT Blue	0 - 255	0 - 65,535	0% - 100%
6	10-11	INT White	0 - 255	0 - 65,535	0% - 100%
RGB					
3	4-5	INT Red	0 - 255	0 - 65,535	0% - 100%
4	6-7	INT Green	0 - 255	0 - 65,535	0% - 100%
5	8-9	INT Blue	0 - 255	0 - 65,535	0% - 100%
CCTHSI					
3	4-5	CCT	0 - 255	0 - 65,535	2000K - 10000K
4	6-7	Green Adjust	0 - 9 10 - 255	0 - 9 10 - 65,535	Neutral (0) Full magenta ~ Full green (-1.0 ~ +1.0)
5	8-9	Crossfade	0 - 255	0 - 65,535	0% - 100%
6	10-11	Hue	0 - 255	0 - 65,535	0° - 360°
7	12-13	Saturation	0 - 255	0 - 65,535	0% - 100%
ICTHS					

3	4-5	CCT	0 - 255	0 - 65,535	2000K - 10000K
4	6-7	Green Adjust	0 - 9 10 - 255	0 - 9 10 - 65,535	Neutral (0) Full magenta ~ Full green (-1.0 ~ +1.0)
5	8-9	Hue	0 - 255	0 - 65,535	0° - 360°
6	10-11	Saturation	0 - 255	0 - 65,535	0% - 100%
CCTRGBW					
3	4-5	CCT	0 - 255	0 - 65,535	2000K - 10000K
4	6-7	Green Adjust	0 - 9 10 - 255	0 - 9 10 - 65,535	Neutral (0) Full magenta ~ Full green (-1.0 ~ +1.0)
5	8-9	Crossfade	0 - 255	0 - 65,535	0% - 100%
6	10-11	INT Red	0 - 255	0 - 65,535	0% - 100%
7	12-13	INT Green	0 - 255	0 - 65,535	0% - 100%
8	14-15	INT Blue	0 - 255	0 - 65,535	0% - 100%
9	16-17	INT White	0 - 255	0 - 65,535	0% - 100%
ICTRGBW					
3	4-5	CCT	0 - 255	0 - 65,535	2000K - 10000K
4	6-7	Green Adjust	0 - 9 10 - 255	0 - 9 10 - 65,535	Neutral (0) Full magenta ~ Full green (-1.0 ~ +1.0)
5	8-9	INT Red	0 - 255	0 - 65,535	0% - 100%
6	10-11	INT Green	0 - 255	0 - 65,535	0% - 100%
7	12-13	INT Blue	0 - 255	0 - 65,535	0% - 100%
8	14-15	INT White	0 - 255	0 - 65,535	0% - 100%
CCTxy					
3	4-5	CCT	0 - 255	0 - 65,535	2000K - 10000K
4	6-7	Green Adjust	0 - 9 10 - 255	0 - 9 10 - 65,535	Neutral (0) Full magenta ~ Full green (-1.0 ~ +1.0)
5	8-9	Crossfade	0 - 255	0 - 65,535	0% - 100%
6	10-11	x	0 - 255	0 - 65,535	0.0 - 0.8
7	12-13	y	0 - 255	0 - 65,535	0.0 - 0.8
ICTxy					
3	4-5	CCT	0 - 255	0 - 65,535	2000K - 10000K
4	6-7	Green Adjust	0 - 9 10 - 255	0 - 9 10 - 65,535	Neutral (0) Full magenta ~ Full green (-1.0 ~ +1.0)
5	8-9	x	0 - 255	0 - 65,535	0.0 - 0.8

6	10-11	y	0 - 255	0 - 65, 535	0.0 - 0.8
		GEL			
3	4-5	Gel Filter	0 - 9 10 - 19 20 - 29 30 - 39 40 - 49 50 - 59 60 - 69 70 - 79 80 - 89 90 - 99 100 - 109 110 - 119 120 - 129 130 - 139 140 - 149 150 - 159 160 - 169 170 - 179 180 - 189 190 - 199 200 - 209 210 - 255	None Bastard Amber Straw Light Amber Light Flame Golden Amber Light Red No Color Pink Middle Rose Light Rose Purple Surprise Pink No Color Blue Daylight Blue Primary Blue Moss Green Blue Green Gel 1 Gel 2 Gel 3 Gel 4 Gel 5 Reserved	
4	6-7	CCT	0 - 99 100 - 255	3200K 6500K	
		DEMO			
3	4-5	Demo Selection	0 - 9 10 - 19 20 - 29 30 - 39 40 - 49 50 - 59 60 - 69 70 - 79 80 - 89 90 - 99 100 - 109 110 - 119 120 - 129 130 - 139 140 - 255	No effect(Stop Effect) Candle Club light Color chase Cop car Fireworks Lightning Paparazzi Strobe Television Circular (Only for PIX mode) Vertical (Only for PIX mode) Horizontal (Only for PIX mode) Diagonal (Only for PIX mode) Reserved for future use	
4	6-7	Function 1	See table below		
5	8-9	Function 2			
6	10-11	Function 3			

13 - DMX MAPPING

		Candle			Fireworks			Television		
8-bit DMX X	16-bit DMX	Function	8-bit/16-bit Value	Range	Function	8-bit/16-bit Value	Range	Function	8-bit/16-bit Value	Range
4	6-7	Color	0 - 9 10 - 19 20 - 29	Warmer Neutral Cooler	Color	0 - 9 10 - 19 20 - 29	Color White Color + White	Mode	0 - 9 10 - 19 20 - 29 30 - 39	Action Horror News Romance
5	8-9	Speed	0 - 9 10 - 19 20 - 29 30 - 39 40 - 49	Slowest Slower Medium Faster Fastest	Speed	0 - 9 10 - 19 20 - 29 30 - 39 40 - 49	Slowest Slower Medium Faster Fastest			
		Club Light			Lightning			Cop Car		
4	6-7	Color	0 - 9 10 - 19 20 - 29 30 - 39 40 - 49 50 - 59 60 - 69	Red Green Blue Cyan Magenta Yellow All colors	Color	0 - 9 10 - 19 20 - 29	Warmer Neutral Cooler	Color	0 - 9 10 - 19 20 - 29 30 - 39 40 - 49 50 - 59 60 - 69 70 - 79 80 - 89 90 - 99 100 - 109	B (Blue) R (Red) A (Amber) W (White) RB RA BA BW AW RBW BRA
5	8-9	Speed	0 - 9 10 - 19 20 - 29 30 - 39 40 - 49	Slowest Slower Medium Faster Fastest	Speed	0 - 9 10 - 19 20 - 29 30 - 39 40 - 49	Slowest Slower Medium Faster Fastest	Flash Pattern	0 - 9 10 - 19 20 - 29 30 - 39	Single Double Quad Quint
		Color Chase			Paparazzi			Strobe		
4	6-7	Saturation	0 - 255/ 0 - 65,535	0% - 100%	Color	0 - 9 10 - 19 20 - 29	Warmer Neutral Cooler	Hue	0 - 255 / 0 - 65,535	0 - 360°
5	8-9	Speed	0 - 9 10 - 19 20 - 29 30 - 39 40 - 49	Slowest Slower Medium Faster Fastest	Speed	0 - 9 10 - 19 20 - 29 30 - 39 40 - 49	Slowest Slower Medium Faster Fastest	Saturation	0 - 255 / 0 - 65,535	0% - 100%
6	10-11							Speed	0 - 9 10 - 19 20 - 29 30 - 39 40 - 49	Slowest Slower Medium Faster Fastest

13 - DMX MAPPING

		Candle			Fireworks			Television		
8-bit DMX	16-bit DMX	Function	8-bit/16-bit Value	Range	Function	8-bit/16-bit Value	Range	Function	8-bit/16-bit Value	Range
4	6-7	Color	0 - 9 10 - 19 20 - 29	Warmer Neutral Cooler	Color	0 - 9 10 - 19 20 - 29	Color White Color + White	Mode	0 - 9 10 - 19 20 - 29 30 - 39	Action Horror News Romance
5	8-9	Speed	0 - 9 10 - 19 20 - 29 30 - 39 40 - 49	Slowest Slower Medium Faster Fastest	Speed	0 - 9 10 - 19 20 - 29 30 - 39 40 - 49	Slowest Slower Medium Faster Fastest			
		Club Light			Lightning			Cop Car		
4	6-7	Color	0 - 9 10 - 19 20 - 29 30 - 39 40 - 49 50 - 59 60 - 69	Red Green Blue Cyan Magenta Yellow All colors	Color	0 - 9 10 - 19 20 - 29	Warmer Neutral Cooler	Color	0 - 9 10 - 19 20 - 29 30 - 39 40 - 49 50 - 59 60 - 69 70 - 79 80 - 89 90 - 99 100 - 109	B (Blue) R (Red) A (Amber) W (White) RB RA BA BW AW RBW BRA
5	8-9	Speed	0 - 9 10 - 19 20 - 29 30 - 39 40 - 49	Slowest Slower Medium Faster Fastest	Speed	0 - 9 10 - 19 20 - 29 30 - 39 40 - 49	Slowest Slower Medium Faster Fastest	Flash Pattern	0 - 9 10 - 19 20 - 29 30 - 39	Single Double Quad Quint

13 - DMX MAPPING

		Color Chase			Paparazzi			Strobe		
4	6-7	Saturation	0 - 255/ 0 - 65,535	0% - 100%	Color	0 - 9 10 - 19 20 - 29	Warmer Neutral Cooler	Hue	0 - 255 / 0 - 65,535	0 - 360°
5	8-9	Speed	0 - 9 10 - 19 20 - 29 30 - 39 40 - 49	Slowest Slower Medium Faster Fastest	Speed	0 - 9 10 - 19 20 - 29 30 - 39 40 - 49	Slowest Slower Medium Faster Fastest	Saturation	0 - 255 / 0 - 65,535	0% - 100%
6	10-11							Speed	0 - 9 10 - 19 20 - 29 30 - 39 40 - 49	Slowest Slower Medium Faster Fastest

13 - DMX MAPPING

Mode 480 (8-bit) / Mode 484 (16-bit) : PXL4 CCTxy						
8-bit DMX	16-bit DMX	Pixel	Function	8-bit/16-bit Value		Range
1	1-2	1	Master Intensity	0 - 255	0 - 65,535	0% - 100%
2	3-4		CCT	0 - 255	0 - 65,535	2000K - 10000K
3	5-6		Green Adjust	0 - 9 10 - 255	0 - 9 10 - 65,535	Neutral (0) Full magenta ~ Full green (-1.0 ~ +1.0)
4	7-8		Crossfade	0 - 255	0 - 65,535	0% - 100%
5	9-10		x	0 - 255	0 - 65,535	0.0 - 0.8
6	11-12		y	0 - 255	0 - 65,535	0.0 - 0.8
7	13-14	2	Master Intensity	0 - 255	0 - 65,535	0% - 100%
8	15-16		CCT	0 - 255	0 - 65,535	2000K - 10000K
9	17-18		Green Adjust	0 - 9 10 - 255	0 - 9 10 - 65,535	Neutral (0) Full magenta ~ Full green (-1.0 ~ +1.0)
10	19-20		Crossfade	0 - 255	0 - 65,535	0% - 100%
11	21-22		x	0 - 255	0 - 65,535	0.0 - 0.8
12	23-24		y	0 - 255	0 - 65,535	0.0 - 0.8
13	25-26	3	Master Intensity	0 - 255	0 - 65,535	0% - 100%
14	27-28		CCT	0 - 255	0 - 65,535	2000K - 10000K
15	29-30		Green Adjust	0 - 9 10 - 255	0 - 9 10 - 65,535	Neutral (0) Full magenta ~ Full green (-1.0 ~ +1.0)
16	31-32		Crossfade	0 - 255	0 - 65,535	0% - 100%
17	33-34		x	0 - 255	0 - 65,535	0.0 - 0.8
18	35-36		y	0 - 255	0 - 65,535	0.0 - 0.8
19	37-38	4	Master Intensity	0 - 255	0 - 65,535	0% - 100%
20	39-40		CCT	0 - 255	0 - 65,535	2000K - 10000K
21	41-42		Green Adjust	0 - 9 10 - 255	0 - 9 10 - 65,535	Neutral (0) Full magenta ~ Full green (-1.0 ~ +1.0)
22	43-44		Crossfade	0 - 255	0 - 65,535	0% - 100%
23	45-46		x	0 - 255	0 - 65,535	0.0 - 0.8

24	47-48		y	0 - 255	0 - 65,535	0.0 - 0.8
25	49		Strobe Frequency	0 - 9 10 - 255		Strobe off 1Hz - 25Hz
26	50		Control	See control table		
27	51		Reserved	TBD		

13 - DMX MAPPING

Mode 481 (8-bit) / Mode 485 (16-bit) : PXL4 ICTHS						
8-bit DMX	16-bit DMX	Pixel	Function	8-bit/16-bit Value		Range
1	1-2	1	Master Intensity	0 - 255	0 - 65,535	0% - 100%
2	3-4		CCT	0 - 255	0 - 65,535	2000K - 10000K
3	5-6		Green Adjust	0 - 9 10 - 255	0 - 9 10 - 65,535	Neutral (0) Full magenta ~ Full green (-1.0 ~ +1.0)
4	7-8		Hue	0 - 255	0 - 65,535	0° - 360°
5	9-10		Saturation	0 - 255	0 - 65,535	0% - 100%
6	11-12	2	Master Intensity	0 - 255	0 - 65,535	0% - 100%
7	13-14		CCT	0 - 255	0 - 65,535	2000K - 10000K
8	15-16		Green Adjust	0 - 9 10 - 255	0 - 9 10 - 65,535	Neutral (0) Full magenta ~ Full green (-1.0 ~ +1.0)
9	17-18		Hue	0 - 255	0 - 65,535	0° - 360°
10	19-20		Saturation	0 - 255	0 - 65,535	0% - 100%
11	21-22	3	Master Intensity	0 - 255	0 - 65,535	0% - 100%
12	23-24		CCT	0 - 255	0 - 65,535	2000K - 10000K
13	25-26		Green Adjust	0 - 9 10 - 255	0 - 9 10 - 65,535	Neutral (0) Full magenta ~ Full green (-1.0 ~ +1.0)
14	27-28		Hue	0 - 255	0 - 65,535	0° - 360°
15	29-30		Saturation	0 - 255	0 - 65,535	0% - 100%
16	31-32	4	Master Intensity	0 - 255	0 - 65,535	0% - 100%
17	33-34		CCT	0 - 255	0 - 65,535	2000K - 10000K
18	35-36		Green Adjust	0 - 9 10 - 255	0 - 9 10 - 65,535	Neutral (0) Full magenta ~ Full green (-1.0 ~ +1.0)
19	37-38		Hue	0 - 255	0 - 65,535	0° - 360°
20	39-40		Saturation	0 - 255	0 - 65,535	0% - 100%
21	41		Strobe Frequency	0 - 9 10 - 255		Strobe off 1Hz - 25Hz

22	42		Control	See control table
23	43		Reserved	TBD

13 - DMX MAPPING

Mode 482 (8-bit) / Mode 486 (16-bit) : PXL4 ICTRGBW						
8-bit DMX	16-bit DMX	Pixel	Function	8-bit/16-bit Value		Range
1	1-2	1	Master Intensity	0 - 255	0 - 65,535	0% - 100%
2	3-4		CCT	0 - 255	0 - 65,535	2000K - 10000K
3	5-6		Green Adjust	0 - 9 10 - 255	0 - 9 10 - 65,535	Neutral (0) Full magenta ~ Full green (-1.0 ~ +1.0)
4	7-8		Intensity Red	0 - 255	0 - 65,535	0% - 100%
5	9-10		Intensity Green	0 - 255	0 - 65,535	0% - 100%
6	11-12		Intensity Blue	0 - 255	0 - 65,535	0% - 100%
7	13-14		Intensity White	0 - 255	0 - 65,535	0% - 100%
8	15-16	2	Master Intensity	0 - 255	0 - 65,535	0% - 100%
9	17-18		CCT	0 - 255	0 - 65,535	2000K - 10000K
10	19-20		Green Adjust	0 - 9 10 - 255	0 - 9 10 - 65,535	Neutral (0) Full magenta ~ Full green (-1.0 ~ +1.0)
11	21-22		Intensity Red	0 - 255	0 - 65,535	0% - 100%
12	23-24		Intensity Green	0 - 255	0 - 65,535	0% - 100%
13	25-26		Intensity Blue	0 - 255	0 - 65,535	0% - 100%
14	27-28		Intensity White	0 - 255	0 - 65,535	0% - 100%
15	29-30	3	Master Intensity	0 - 255	0 - 65,535	0% - 100%
16	31-32		CCT	0 - 255	0 - 65,535	2000K - 10000K
17	33-34		Green Adjust	0 - 9 10 - 255	0 - 9 10 - 65,535	Neutral (0) Full magenta ~ Full green (-1.0 ~ +1.0)
18	35-36		Intensity Red	0 - 255	0 - 65,535	0% - 100%
19	37-38		Intensity Green	0 - 255	0 - 65,535	0% - 100%
20	39-40		Intensity Blue	0 - 255	0 - 65,535	0% - 100%
21	41-42		Intensity White	0 - 255	0 - 65,535	0% - 100%
22	43-44	4	Master Intensity	0 - 255	0 - 65,535	0% - 100%
23	45-46		CCT	0 - 255	0 - 65,535	2000K - 10000K

24	47-48		Green Adjust	0 - 9 10 - 255	0 - 9 10 - 65, 535	Neutral (0) Full magenta ~ Full green (-1.0 ~ +1.0)
25	49-50		Intensity Red	0 - 255	0 - 65, 535	0% - 100%
26	51-52		Intensity Green	0 - 255	0 - 65, 535	0% - 100%
27	53-54		Intensity Blue	0 - 255	0 - 65, 535	0% - 100%
28	55-56		Intensity White	0 - 255	0 - 65, 535	0% - 100%
29	57		Strobe Frequency	0 - 9 10 - 255		Strobe off 1Hz - 25Hz
30	58		Control	See control table		
31	59		Reserved	TBD		

13 - DMX MAPPING

Mode 483 (8-bit) / Mode 487 (16-bit) : PXL4 ICTxy						
8-bit DMX	16-bit DMX	Pixel	Function	8-bit/16-bit Value		Range
1	1-2	1	Master Intensity	0 - 255	0 - 65,535	0% - 100%
2	3-4		CCT	0 - 255	0 - 65,535	2000K - 10000K
3	5-6		Green Adjust	0 - 9 10 - 255	0 - 9 10 - 65,535	Neutral (0) Full magenta ~ Full green (-1.0 ~ +1.0)
4	7-8		x	0 - 255	0 - 65,535	0.0 - 0.8
5	9-10		y	0 - 255	0 - 65,535	0.0 - 0.8
6	11-12	2	Master Intensity	0 - 255	0 - 65,535	0% - 100%
7	13-14		CCT	0 - 255	0 - 65,535	2000K - 10000K
8	15-16		Green Adjust	0 - 9 10 - 255	0 - 9 10 - 65,535	Neutral (0) Full magenta ~ Full green (-1.0 ~ +1.0)
9	17-18		x	0 - 255	0 - 65,535	0.0 - 0.8
10	19-20		y	0 - 255	0 - 65,535	0.0 - 0.8
11	21-22	3	Master Intensity	0 - 255	0 - 65,535	0% - 100%
12	23-24		CCT	0 - 255	0 - 65,535	2000K - 10000K
13	25-26		Green Adjust	0 - 9 10 - 255	0 - 9 10 - 65,535	Neutral (0) Full magenta ~ Full green (-1.0 ~ +1.0)
14	27-28		x	0 - 255	0 - 65,535	0.0 - 0.8
15	29-30		y	0 - 255	0 - 65,535	0.0 - 0.8
16	31-32	4	Master Intensity	0 - 255	0 - 65,535	0% - 100%
17	33-34		CCT	0 - 255	0 - 65,535	2000K - 10000K
18	35-36		Green Adjust	0 - 9 10 - 255	0 - 9 10 - 65,535	Neutral (0) Full magenta ~ Full green (-1.0 ~ +1.0)
19	37-38		x	0 - 255	0 - 65,535	0.0 - 0.8
20	39-40		y	0 - 255	0 - 65,535	0.0 - 0.8
21	41		Strobe Frequency	0 - 9 10 - 255		Strobe off 1Hz - 25Hz

22	42		Control	See control table
23	43		Reserved	TBD

13 - DMX MAPPING

Mode 488 (8-bit) / Mode 492 (16-bit) : PXL4 EZ CCT						
8-bit DMX	16-bit DMX	Pixel	Function	8-bit/16-bit Value		Range
1	1-2	1	Master Intensity	0 - 255	0 - 65,535	0% - 100%
2	3-4		CCT	0 - 255	0 - 65,535	2000K - 10000K
3	5-6		Green Adjust	0 - 9 10 - 255	0 - 9 10 - 65,535	Neutral (0) Full magenta ~ Full green (-1.0 ~ +1.0)
4	7-8	2	Master Intensity	0 - 255	0 - 65,535	0% - 100%
5	9-10		CCT	0 - 255	0 - 65,535	2000K - 10000K
6	11-12		Green Adjust	0 - 9 10 - 255	0 - 9 10 - 65,535	Neutral (0) Full magenta ~ Full green (-1.0 ~ +1.0)
7	13-14	3	Master Intensity	0 - 255	0 - 65,535	0% - 100%
8	15-16		CCT	0 - 255	0 - 65,535	2000K - 10000K
9	17-18		Green Adjust	0 - 9 10 - 255	0 - 9 10 - 65,535	Neutral (0) Full magenta ~ Full green (-1.0 ~ +1.0)
10	19-20	4	Master Intensity	0 - 255	0 - 65,535	0% - 100%
11	21-22		CCT	0 - 255	0 - 65,535	2000K - 10000K
12	23-24		Green Adjust	0 - 9 10 - 255	0 - 9 10 - 65,535	Neutral (0) Full magenta ~ Full green (-1.0 ~ +1.0)

13 - DMX MAPPING

Mode 489 (8-bit) / Mode 493 (16-bit) : PXL4 EZ HSI						
8-bit DMX	16-bit DMX	Pixel	Function	8-bit/16-bit Value		Range
1	1-2	1	Master Intensity	0 - 255	0 - 65,535	0% - 100%
2	3-4		Hue	0 - 255	0 - 65,535	0° - 360°
3	5-6		Saturation	0 - 255	0 - 65,535	0% - 100%
4	7-8	2	Master Intensity	0 - 255	0 - 65,535	0% - 100%
5	9-10		Hue	0 - 255	0 - 65,535	0° - 360°
6	11-12		Saturation	0 - 255	0 - 65,535	0% - 100%
7	13-14	3	Master Intensity	0 - 255	0 - 65,535	0% - 100%
8	15-16		Hue	0 - 255	0 - 65,535	0° - 360°
9	17-18		Saturation	0 - 255	0 - 65,535	0% - 100%
10	19-20	4	Master Intensity	0 - 255	0 - 65,535	0% - 100%
11	21-22		Hue	0 - 255	0 - 65,535	0° - 360°
12	23-24		Saturation	0 - 255	0 - 65,535	0% - 100%

13 - DMX MAPPING

Mode 490 (8-bit) / Mode 494 (16-bit) : PXL4 EZ RGBW						
8-bit DMX	16-bit DMX	Pixel	Function	8-bit/16-bit Value		Range
1	1-2	1	Master Intensity	0 - 255	0 - 65,535	0% - 100%
2	3-4		Intensity Red	0 - 255	0 - 65,535	0% - 100%
3	5-6		Intensity Green	0 - 255	0 - 65,535	0% - 100%
4	7-8		Intensity Blue	0 - 255	0 - 65,535	0% - 100%
5	9-10		Intensity White	0 - 255	0 - 65,535	0% - 100%
6	11-12	2	Master Intensity	0 - 255	0 - 65,535	0% - 100%
7	13-14		Intensity Red	0 - 255	0 - 65,535	0% - 100%
8	15-16		Intensity Green	0 - 255	0 - 65,535	0% - 100%
9	17-18		Intensity Blue	0 - 255	0 - 65,535	0% - 100%
10	19-20		Intensity White	0 - 255	0 - 65,535	0% - 100%
11	21-22	3	Master Intensity	0 - 255	0 - 65,535	0% - 100%
12	23-24		Intensity Red	0 - 255	0 - 65,535	0% - 100%
13	25-26		Intensity Green	0 - 255	0 - 65,535	0% - 100%
14	27-28		Intensity Blue	0 - 255	0 - 65,535	0% - 100%
15	29-30		Intensity White	0 - 255	0 - 65,535	0% - 100%
16	31-32	4	Master Intensity	0 - 255	0 - 65,535	0% - 100%
17	33-34		Intensity Red	0 - 255	0 - 65,535	0% - 100%
18	35-36		Intensity Green	0 - 255	0 - 65,535	0% - 100%
19	37-38		Intensity Blue	0 - 255	0 - 65,535	0% - 100%
20	39-40		Intensity White	0 - 255	0 - 65,535	0% - 100%

13 - DMX MAPPING

Mode 491 (8-bit) / Mode 495 (16-bit) : PXL4 EZ RGB						
8-bit DMX	16-bit DMX	Pixel	Function	8-bit/16-bit Value		Range
1	1-2	1	Intensity Red	0 - 255	0 - 65,535	0% - 100%
2	3-4		Intensity Green	0 - 255	0 - 65,535	0% - 100%
3	5-6		Intensity Blue	0 - 255	0 - 65,535	0% - 100%
4	7-8	2	Intensity Red	0 - 255	0 - 65,535	0% - 100%
5	9-10		Intensity Green	0 - 255	0 - 65,535	0% - 100%
6	11-12		Intensity Blue	0 - 255	0 - 65,535	0% - 100%
7	13-14	3	Intensity Red	0 - 255	0 - 65,535	0% - 100%
8	15-16		Intensity Green	0 - 255	0 - 65,535	0% - 100%
9	17-18		Intensity Blue	0 - 255	0 - 65,535	0% - 100%
10	19-20	4	Intensity Red	0 - 255	0 - 65,535	0% - 100%
11	21-22		Intensity Green	0 - 255	0 - 65,535	0% - 100%
12	23-24		Intensity Blue	0 - 255	0 - 65,535	0% - 100%

14 - RDM FUNCTIONS

Table of Contents	Page
RDM Identification	69
DMX Personality Identification	70
Network Management	73
Status Collection	73
RDM Information	73
Product Information	74
DMX512 Setup	74
Dimmer Settings RDM E1.37 version (not supported yet)	74
Power/Lamp Settings	75
Control	75
Manufacturer Command	75

14 - RDM FUNCTIONS

RDM Identification			
Manufacturer ID	Device Model ID	Device Label Device	Model Name
6124	30	FLXP3CLR	P3 COLOR
	31	FLXQ5CLR	Q5 COLOR
	32	FLXQ8CLR	Q8 COLOR
	33	FLXMXCLR	Matrix COLOR
	35	FLXQ10CLRRLR	Q10 COLOR-LR
	36	FLXQUADCLR	QUAD COLOR
	37	FLXQ8CLRRLR	Q8 COLOR-LR
	39	FLXMOTOQUADCLR	MOTOQUAD
	3A	FLXG3CLR	G3 COLOR
	3B	FLXQ3CLRRLR	Q3 COLOR-LR
	3F	FLXRPU	RPU
	40	FLXMOTOK40	MOTOK40
	41	FLXQ6CLR	Q6 COLOR
	42	FLXG6CLR	G6 COLOR
	43	FLXMOTOQ3	MOTOQ3
44	FLXK10CLR	K10 COLOR	

UID Example

612435010002

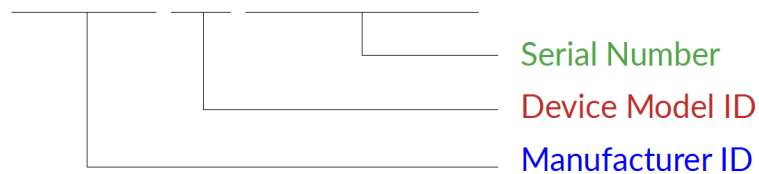

14 - RDM FUNCTIONS

Personality Description	Hex	Description [Decimal Data: Mode Description (Footprint)]
	Matrix/ K10	
1	0x01	1: CCT 8-bit (Footprint 6)
2	0x02	2: HSI 8-bit (Footprint 6)
3	0x03	3: RGBW 8-bit (Footprint 8)
4	0x04	4: CCTHSI 8-bit (Footprint 9)
5	0x05	5: CCTRGBW 8-bit (Footprint 11)
6	0x06	6: CIExy 8-bit (Footprint 6)
7	0x07	7: GEL 8-bit (Footprint 6)
8	0x08	9: CCT 16-bit (Footprint 10)
9	0x09	10: HSI 16-bit (Footprint 10)
10	0x0A	11: RGBW 16-bit (Footprint 14)
11	0x0B	12: CCTHSI 16-bit (Footprint 16)
12	0x0C	13: CCTRGBW 16-bit (Footprint 20)
13	0x0D	14: CIExy 16-bit (Footprint 10)
14	0x0E	15: GEL 16-bit (Footprint 8)
15	0x0F	17: PXL4 CCTHSI 8-bit (Footprint 27)
16	0x010	18: PXL4 CCTRGBW 8-bit (Footprint 35)
17	0x011	19: PXL4 CIExy 8-bit (Footprint 15)
18	0x012	20: PXL4 CCTHSI 16-bit (Footprint 52)
19	0x013	21: PXL4 CCTRGBW 16-bit (Footprint 68)
20	0x014	22: PXL4 CIExy 16-bit (Footprint 28)
21	0x015	40: RGB 8-bit (Footprint 6)
22	0x016	41: CCTxy 8-bit (Footprint 9)
23	0x017	42: ICTHS 8-bit (Footprint 9)
24	0x018	43: ICTRGBW 8-bit (Footprint 11)
25	0x019	44: ICTxy 8-bit (Footprint 9)
26	0x01A	45: RGB 16-bit (Footprint 9)
27	0x01B	46: CCTxy 16-bit (Footprint 15)
28	0x01C	47: ICTHS 16-bit (Footprint 14)
29	0x01D	48: ICTRGBW 16-bit (Footprint 18)
30	0x01E	49: ICTxy 16-bit (Footprint 14)
31	0x01F	50: EZ CCT 8-bit (Footprint 3)
32	0x020	51: EZ HSI 8-bit (Footprint 3)
33	0x021	52: EZ RGBW 8-bit (Footprint 5)

14 - RDM FUNCTIONS

34	0x022	53: EZ CCTHSI 8-bit (Footprint 6)
35	0x023	54: EZ CCTRGBW 8-bit (Footprint 8)
36	0x024	55: EZ CIExy 8-bit (Footprint 3)
37	0x025	56: EZ RGB 8-bit (Footprint 3)
38	0x026	57: EZ CCTxy 8-bit (Footprint 6)
39	0x027	58: EZ ICTHS 8-bit (Footprint 5)
40	0x028	59: EZ ICTRGBW 8-bit (Footprint 7)
41	0x029	60: EZ ICTxy 8-bit (Footprint 5)
42	0x02A	61: EZ 3200K 8-bit (Footprint 1)
43	0x02B	62: EZ 5600K 8-bit (Footprint 1)
44	0x02C	63: EZ CCT 16-bit (Footprint 6)
45	0x02D	64: EZ HSI 16-bit (Footprint 6)
46	0x02E	65: EZ RGBW 16-bit (Footprint 10)
47	0x02F	66: EZ CCTHSI 16-bit (Footprint 12)
48	0x030	67: EZ CCTRGBW 16-bit (Footprint 16)
49	0x031	68: EZ CIExy 16-bit (Footprint 6)
50	0x032	69: EZ RGB 16-bit (Footprint 6)
51	0x033	70: EZ CCTxy 16-bit (Footprint 12)
52	0x034	71: EZ ICTHS 16-bit (Footprint 10)
53	0x035	72: EZ ICTRGBW 16-bit (Footprint 14)
54	0x036	73: EZ ICTxy 16-bit (Footprint 10)
55	0x037	61: EZ 3200K 8-bit (Footprint 1)
56	0x038	75: EZ 5600K 16-bit (Footprint 2)
57	0x039	76: ALL MODES 8-bit (Footprint 12)
58	0x03A	77: ALL MODES 16-bit (Footprint 20)
59	0x03B	80: PXL4 CCTxy 8-bit (Footprint 27)
60	0x03C	81: PXL4 ICTHS 8-bit (Footprint 24)
61	0x03D	82: PXL4 ICTRGBW 8-bit (Footprint 32)
62	0x03E	83: PXL4 ICTxy 8-bit (Footprint 24)
63	0x03F	84: PXL4 CCTxy 16-bit (Footprint 51)
64	0x040	85: PXL4 ICTHS 16-bit (Footprint 44)
65	0x041	86: PXL4 ICTRGBW 16-bit (Footprint 60)
66	0x042	87: PXL4 ICTxy 16-bit (Footprint 44)
67	0x043	88: PXL4 EZ CCT 8-bit (Footprint 12)
68	0x044	89: PXL4 EZ HSI 8-bit (Footprint 12)
69	0x045	90: PXL4 EZ RGBW 8-bit (Footprint 20)

14 - RDM FUNCTIONS

70	0x046	91: PXL4 EZ RGB 8-bit (Footprint 12)
71	0x047	92: PXL4 EZ CCT 16-bit (Footprint 24)
72	0x048	93: PXL4 EZ HSI 16-bit (Footprint 24)
73	0x049	94: PXL4 EZ RGBW 16-bit (Footprint 40)
74	0x04A	95: PXL4 EZ RGB 16-bit (Footprint 24)

14 - RDM FUNCTIONS

Network Management		
Command	PID	Description
DISC UNIQUE BRANCH	0x0001	Devices respond to discovery messages.
DISC MUTE	0x0002	Mute the device.
DISC UNMUTE	0x0003	Unmute the device.

Status Collection (For Art-Net)		
Command	PID	Description
QUEUED MESSAGE	0x0020	The QUEUED_MESSAGE parameter shall be used to retrieve a message from the responder's message queue.

RDM Information		
Command	PID	Description
SUPPORTED PARAMETERS	0x0050	Support required only if supporting parameters beyond the minimum required set.
PARAMETER DESCRIPTION	0x0051	Retrieves a list of all manufacturer commands (\geq 0x8000).

14 - RDM FUNCTIONS

Product Information		
Command	PID	Description
DEVICE INFO	0x0060	This parameter is used to retrieve a variety of information about the device that is normally required by a controller
DEVICE MODEL DESCRIPTION	0x0080	This parameter provides a text description of up to 32 characters for the device model type.
MANUFACTURER LABEL	0x0081	This parameter provides an ASCII text response of up to 32 characters with the Manufacturer name for the device. The Manufacturer name must be consistent between all products manufactured within an ESTA Manufacturer ID.
DEVICE LABEL	0x0082	This parameter provides a means of setting a descriptive label for each device.
SOFTWARE VERSION LABEL	0x00C0	This parameter is used to get a descriptive ASCII text label for the device's operating software version.

DMX512 Setup		
Command	PID	Description
DMX PERSONALITY	0x00E0	This parameter is used to set the responder's DMX512 Personality.
DMX PERSONALITY DESCRIPTION	0x00E1	This parameter is used to get a descriptive ASCII text label for a given DMX512 Personality.
DMX START ADDRESS	0x00F0	This parameter is used to set or get the DMX512 start address.

Dimmer Settings (not yet supported) RDM ANSI E1.37 version		
Command	PID	Description
CURVE	0x0343	Retrieve or set a dimmer curve. 1 : Linear 2 : Gamma
CURVE DESCRIPTION	0x0344	This parameter is used to get a descriptive ASCII text label for a given curve.

14 - RDM FUNCTIONS

Power/Lamp Settings		
Command	PID	Description
DEVICE HOURS	0x0400	This parameter is used to retrieve or set the number of hours of operation the device has been in use.
LAMP HOURS	0x0401	This parameter is used to retrieve the number of lamp hours or to set the counter in the device to a specific starting value.

Control		
Command	PID	Description
IDENTIFY DEVICE	0x1000	This parameter is used for the user to physically identify the device represented by the UID.

Manufacturer Command (not yet supported)		
Command	PID	Description
WHITE POINT	0x8001	GET/SET Range 2000 ~ 10000 Kelvin Applies to HSI, RGBW and RGB modes
FIILEX_FAN	0x8002	GET/SET 0:Silent, 1:Auto, 2:Full speed, 3:OFF
FIILEX_ERROR	0x8003	GET Fiilex error code
FIILEX_CIEXY	0x8004	GET Format: (X, Y) Range: X: 0~0.8 Y: 0~0.8

15 - ACCESSORIES ADJUSTMENTS

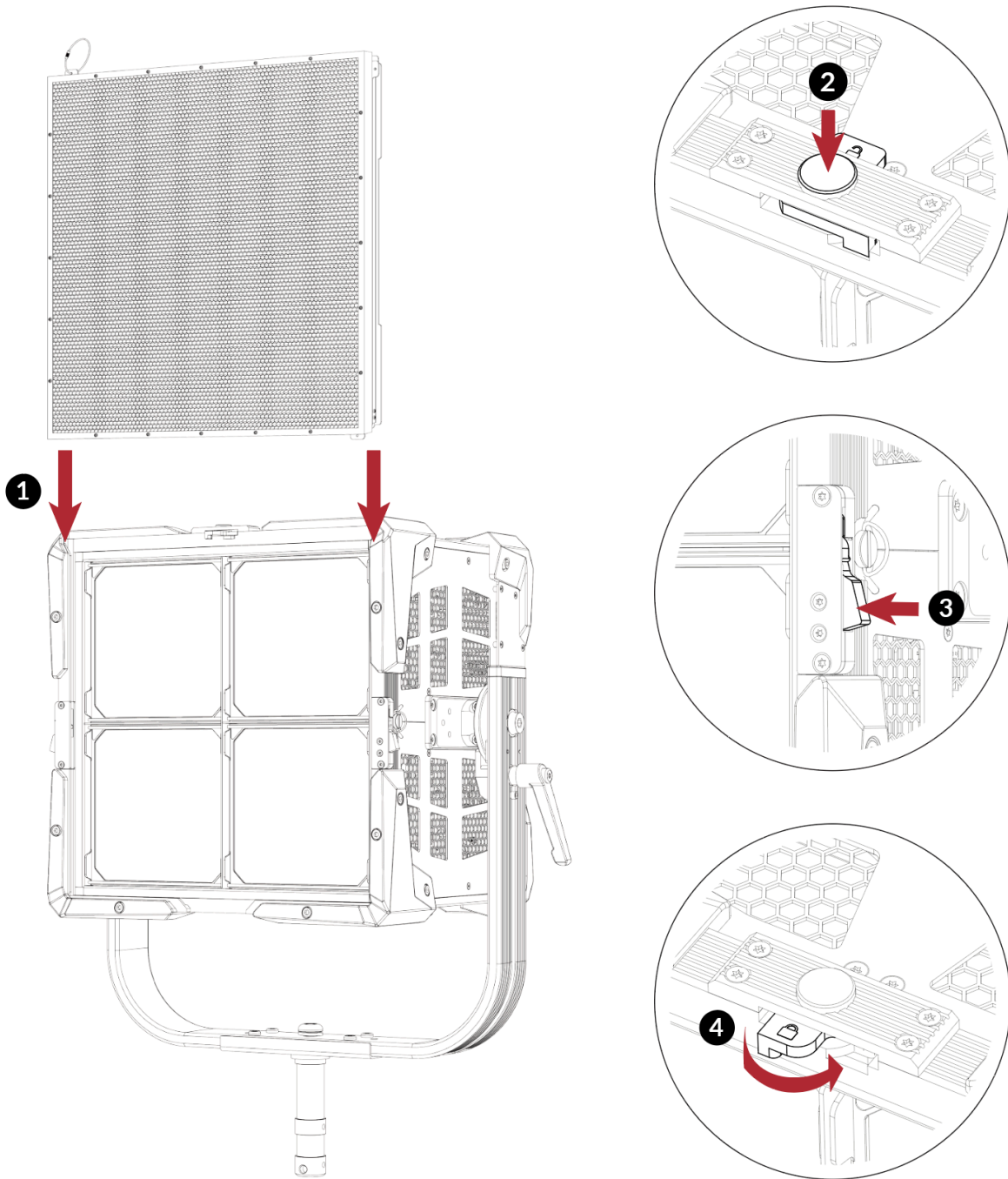

Slide the Honeycomb directly into K10 (1). The side lock will automatically engage. Push button (2) on the top of the K10 lock to secure it.

NOTE: To remove the accessory, press the side locks (3) on both sides and push the front button (4) inward to release the Honeycomb.

15 - ACCESSORIES ADJUSTMENTS

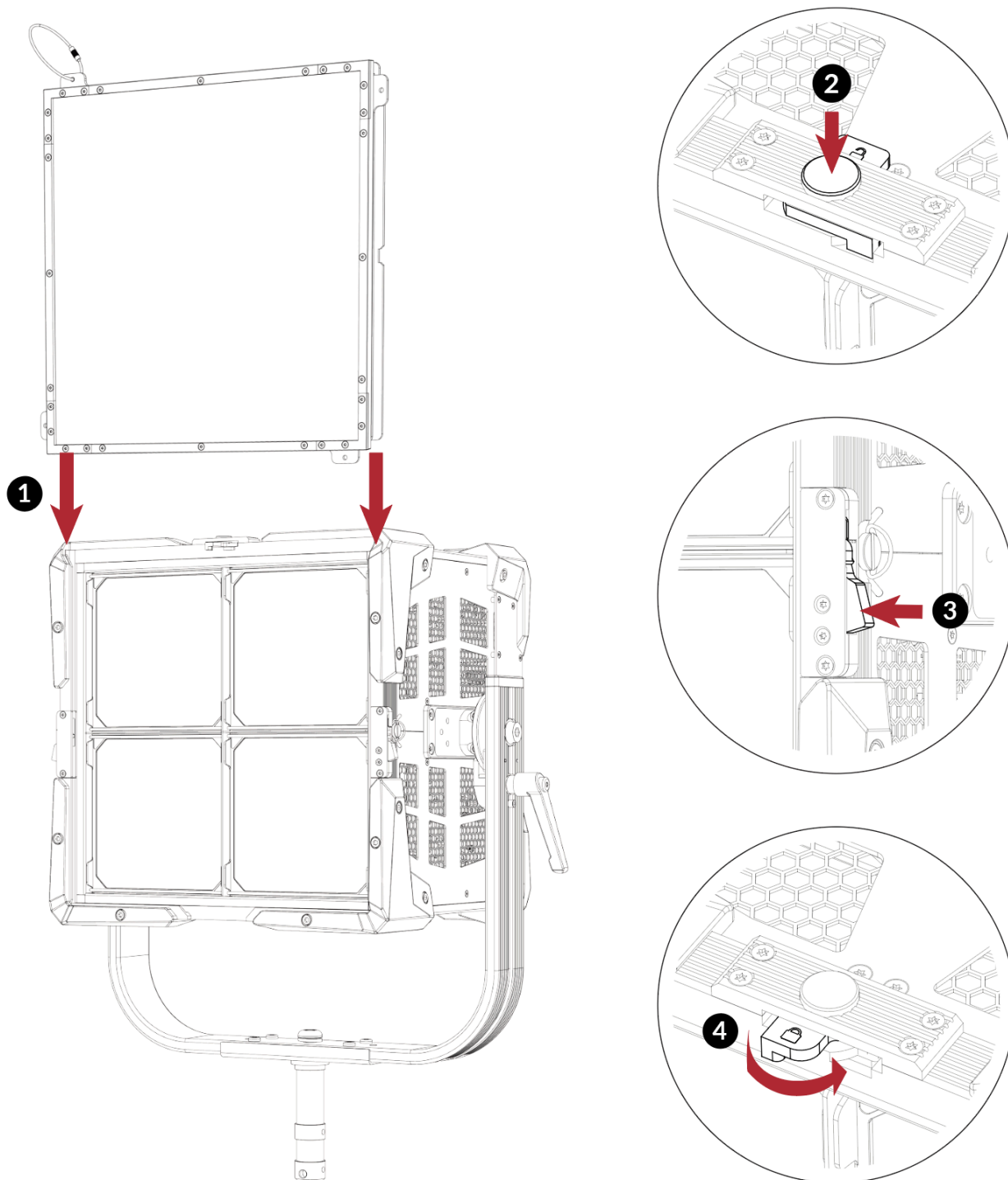

Slide the Diffuser b directly into K10 (1). The side lock will automatically engage. Push button (2) on the top of the K10 lock to secure it.

NOTE: To remove the accessory, press the side locks (3) on both sides and push the front button (4) inward to release the Diffuser.

15 - ACCESSORIES ADJUSTMENTS

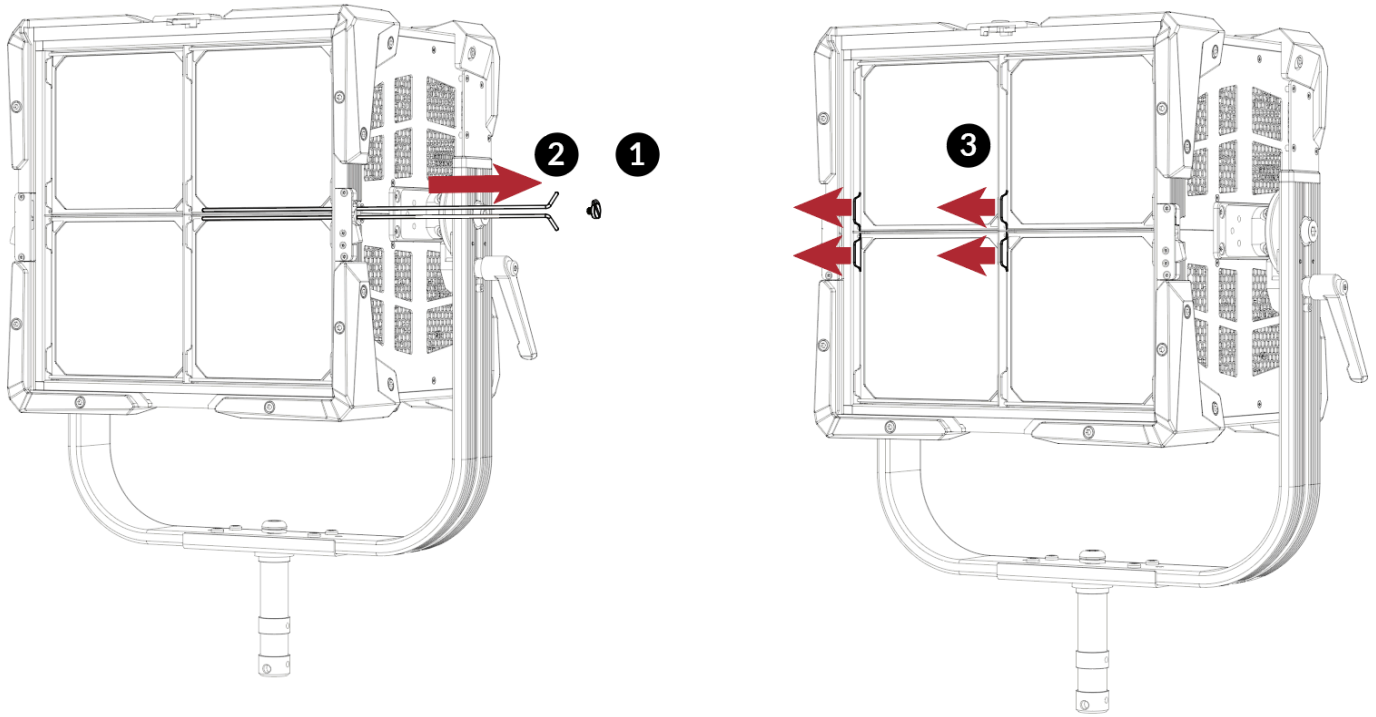

To change lenses, release screw (1). Pull the iron wire (2) outward. Drag the lens corner piece (3).
NOTE: To secure lenses, reverse the process.

Additional accessories



FLXRP-HEAD



FLXK10CLR-FRNL12
(Pack of 4)

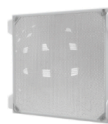

FLXK10CLR-FRNL18
(Pack of 4)

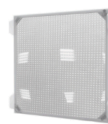

FLXK10CLR-FRNL30
(Pack of 4)



FLXK10CLR-FRNL50
(Pack of 4)



FLXK10CLR-
LIGHTDIFF



FLXK10CLR-
HONEYCOMB



FLXK10CLR-FLUSHCLP

16 - MAINTENANCE

Maintenance and cleaning the product.

Warning! Disconnect from AC power before starting any maintenance work it is recommended to clean the lens at regular intervals to remove any dust, smoke, or other particles to ensure that the light is radiated at maximum brightness.

- For cleaning, disconnect the main plug from the socket. Use a soft, clean cloth moistened with a mild detergent. Then carefully wipe the fixture dry. For cleaning other housing parts use only a soft, clean cloth. Never use a liquid cleaning product, it might penetrate the unit and cause damage to it.
- The user must clean the product periodically to maintain optimum performance and cooling. The user may also upload firmware (product software) to the fixture via the USB-C port using firmware and instructions from Fiilex.
- The frequency of such maintenance operations is to be performed according to various factors, such as the amount of use and the condition of the installation environment (air humidity, presence of dust, salinity, etc.).
- Only use neutral soap and water, then dry it carefully with a soft, non-abrasive cloth.

It is recommended that the product is subject to annual service by a qualified technician for special maintenance involving at least the following procedures:

- » General cleaning of internal parts.
- » General visual check of the internal components, cabling, mechanical parts, etc.
- » Electrical, photometric and functional checks; eventual repairs.

Warning! The use of alcohol or any other detergent could damage the lenses.

- All other service operations on the product must be carried out by Fiilex, its approved service agents or trained and qualified personnel.
- It is Fiilex policy to apply the strictest possible calibration procedures and use the best quality materials available to ensure optimum performance and the longest possible component lifetimes. However, optical components are subject to wear and tear over the life of the product, resulting in gradual changes in colors over many thousands of hours of use. The extent of wear and tear depends heavily on operating conditions and environment, so it is impossible to specify precisely whether and to what extent performance will be affected. However, you may eventually need to replace optical components if their characteristics are affected by wear and tear after an extended period of use and if you require fixtures to perform within very precise optical and color parameters.
- Do not apply filters, lenses or other materials to lenses or other optical components. Use only accessories approved by Fiilex.

16 - MAINTENANCE

Visual check of product housing

- The parts of the product cover/housing should be checked for signs of damage at least every two months. In addition, the front lens holder should be checked mechanically to ensure if it is firmly fastened to the fixture. If any damage is found, do not use the product until the damaged part has been replaced.
- Cracks or another damages to the cover/housing parts can be caused by improper handling or transportation.
- These checks are necessary for both fixed installations and mobile or rental products. Any free moving parts inside of the product, cracked cover or housing or any part of front lens not sitting properly in place need to be immediately replaced.

17 - TROUBLESHOOTING

Problems	Possible causes	Checks and remedies
Product doesn't power ON	<ul style="list-style-type: none"> No power to the product. 	<ul style="list-style-type: none"> Check that power is switched ON and cables are plugged in.
	<ul style="list-style-type: none"> Internal fault. 	<ul style="list-style-type: none"> Contact the Fiilex Service or authorized service partner. Do not remove parts and/or covers, or carry out any repairs or service that are not described in this Safety and User Manual unless you have both authorization from Fiilex and the service documentation.
Product has been reset but does not respond correctly to the controller.	<ul style="list-style-type: none"> Bad signal connection. 	<ul style="list-style-type: none"> Inspect connections and cables. Fix any bad connections. Repair or replace damaged cables.
	<ul style="list-style-type: none"> Signal connection not terminated. 	<ul style="list-style-type: none"> Insert DMX termination plug in signal output socket of the last product on the signal line.
	<ul style="list-style-type: none"> Incorrect addressing of the product. 	<ul style="list-style-type: none"> Check the product address and control settings.
	<ul style="list-style-type: none"> One of the products is defective and is corrupting the signal transmission on the signal line. 	<ul style="list-style-type: none"> Unplug the XLR in and out connectors and connect them directly together to bypass one product at a time until normal operation is regained. Once the error has been identified, have that fixture serviced by a qualified technician.
Fresnel adjustment is too firm/not firm enough	<ul style="list-style-type: none"> Mechanical hardware requires cleaning, adjustment or lubrication. 	<ul style="list-style-type: none"> Contact Fiilex Service or an authorized service partner.
Light output turns OFF Intermittently	<ul style="list-style-type: none"> Fixture is too hot. 	<ul style="list-style-type: none"> Check product for error messages. Allow product to cool. Clean the product and vents. Reduce ambient temperature.
	<ul style="list-style-type: none"> Hardware failure (temperature sensor, fans, Light source...) 	<ul style="list-style-type: none"> Check product for error messages for more information. Contact Fiilex Service or an authorized service partner.
General low light intensity	<ul style="list-style-type: none"> Dirty lens assembly. Dirty or damaged filters. 	<ul style="list-style-type: none"> Clean the fixture regularly. Install lens assembly properly.

Contact an authorized service center in case of technical problems or not reported in the table can not be resolved by the procedure given in the table.

18 - ERROR CODES LIST

Error Code	Description	Troubleshooting Steps	Notes
5	Fan RPM Reading 0	<ul style="list-style-type: none"> • Reboot Fixture • Ensure Fan is Spinning • Ensure vents are free from debris • Contact filex@filex.com 	
6	System Boot Up Error	<ul style="list-style-type: none"> • Reboot Fixture • Contact filex@filex.com 	
7	FLASH	<ul style="list-style-type: none"> • Reboot Fixture • Contact filex@filex.com 	
8	Temperature Reading Error	<ul style="list-style-type: none"> • Ensure ambient operating temp is above 32 and below 104 F • Reboot Fixture • Contact filex@filex.com 	
11-18	Driver Board Disconnect	<ul style="list-style-type: none"> • Reboot Fixture • Dry fixture thoroughly (8+ hours) if subject to rain or high humidity • Contact filex@filex.com 	<ul style="list-style-type: none"> • Error code number indicates which component caused error. Provide this to Fiilex Customer Service if unable to resolve • K40 / MOTOK40 can operate with error codes. 2 pixels will not illuminate
20-54	Component Over Temp	<ul style="list-style-type: none"> • Ensure ambient operating temp is below 104 F • Check fixture vents for sign of blockage • Check if fans are spinning • Reboot Fixture • Clean fixture • Contact filex@filex.com 	<ul style="list-style-type: none"> • Error code number indicates which component caused error. Provide this to Fiilex Customer Service if unable to resolve
60	Error with Panning sensors	<ul style="list-style-type: none"> • Reboot Fixture • Release Latches to Manually control Yoke • Check if any roughness while panning • If exposed to water, allow fixture to dry for 8+ hours • Check if angle values change while manually panning 	
61	Error with Tilting sensors	<ul style="list-style-type: none"> • Reboot Fixture • Release Latches to Manually control Yoke • Check if any roughness while tilting • If exposed to water, allow fixture to dry for 8+ hours • Check if angle values change while manually tilting 	

Contact an authorized service center in case of technical problems or not reported in the table can not be resolved by the procedure given in the table.

18 - ERROR CODES LIST

Error Code	Description	Troubleshooting Steps	Notes
70-74	System Boot Up Error	<ul style="list-style-type: none"> • Ensure power inputs are supplying the correct voltage. • Reboot Fixture. • Contact filex@filex.com 	
75	Insufficient Voltage (Main Circuit)	<ul style="list-style-type: none"> • Ensure power inputs are supplying the correct voltage • Use a new power source to main input • Replace power cable • Reboot fixture • Contact filex@filex.com 	
76	Insufficient Voltage (Secondary Circuit)	<ul style="list-style-type: none"> • Ensure power inputs are supplying the correct voltage • Use a new power source to secondary input • Replace power cable • Reboot fixture • Contact filex@filex.com 	

Contact an authorized service center in case of technical problems or not reported in the table can not be resolved by the procedure given in the table.